

Reference Schematics For RK3528

RK3528_BOX_REF_SCH_V10

Main Functions Introduction

- 1) Power: DiscretePower:BUCK+LDO or PMIC RK805-6
- 2) RAM: DDR3 4x16bit
DDR4 2x16Bit
DDR4 4x16Bit
LPDDR3 1x32bit
LPDDR4/LPDDR4X 1x32bit
- 3) ROM: eMMC5.1 or FSPI Flash
- 4) Support: Micro SD Card3.0
- 5) Support: 1 x USB3.0 OTG + 1 x USB2.0 HOST
- 6) Support: 1 x HDMI2.0 TX
- 7) Support: 1 x AV OUT
- 8) Support: SDIO WiFi5 + UART/PCM BT
PCIE WIFI5 + UART/PCM BT
- 9) Support: 1 x Ethernet(Embed PHY) + 1x Ethernet(RGMII or RMII)
- 10) Support: Optical S/PDIF TX
- 11) Support: IR Receiver
- 12) Support: Audio-MicArray 2xI2S-DMIC or 4xPDM-DMIC
- 13) Support: RECOVER/RESET/SARADC_BOOT_KEY,HW_ID
- 14) Support: 1 x PCIE2.0 Slot
- 15) Support: Debug UART

https://www.nas-ya.com/		
Title	HT2	
Size	Document Number	Rev
A4	<Doc>	<Rev>
Date:	Friday, April 12, 2024	Sheet 1 of 23

Table of Content

Page 1	00.Cover Page
Page 2	01.Index and Notes
Page 3	02.Revision History
Page 4	03.Block Diagram
Page 5	04.Power Tree-DiscretePower
Page 6	04.Power Tree-PMIC RK805-6
Page 7	05.Power Sequence-DiscretePower
Page 8	05.Power Sequence-PMIC RK805-6
Page 9	06.UART Map
Page 10	07.I2C Bus Map
Page 11	08.USB3/PCIE Fun Map
Page 12	10.RK3528 Power/GND
Page 13	11.RK3528 OSC/PLL/PMUIO
Page 14	12.RK3528 DDR Controller
Page 15	13.RK3528 FLASH/SD Controller
Page 16	14.RK3528 USB/PCIE Controller
Page 17	15.RK3528 SARADC/OTP
Page 18	16.RK3528 HDMI Interface
Page 19	17.RK3528 AV OUT
Page 20	18.RK3528 Embed FEPHY
Page 21	19.RK3528_1.8V/3.3V GPIO
Page 22	20.Power-DCIN
Page 23	21.Power-DiscretePower
Page 24	22.Power-PMIC-RK805-6(OPTION)
Page 25	25.USB2/USB3 Port
Page 26	30.DRAM DDR3 4x16bit_96P
Page 27	30.DRAM-DDR4_2x16Bit_96P
Page 28	30.DRAM-DDR4_4x16Bit_96P
Page 29	30.DRAM-LPDDR3_1X32bit_178P
Page 30	30.DRAM-LPDDR4_1X32bit_200P
Page 31	30.DRAM-LPDDR4X_1X32bit_200P
Page 32	40.Flash-eMMC
Page 33	42.Flash-Micro-SD Card
Page 34	43.Flash-SPI FLASH(Option)
Page 35	50.VO-HDMI TX
Page 36	51.VO-AV Interface
Page 37	61.WIF/BT-SDIO_2T2R_AP6275S
Page 38	62.WIF/BT-SDIO_2T2R_RTL8822CS
Page 39	63.WIFI6/BT-PCIe_2T2R_AP6275P
Page 40	65.10/100M-Embed PHY
Page 41	66.Ethernet-FEPHY_RMII
Page 42	67.Ethernet-GEPHY_RGMII
Page 43	76.Audio-Headphone/MICIN
Page 44	77.Audio-MicArray(2xI2S-DMIC)
Page 45	78.Audio-MicArray(4xPDM-DMIC)
Page 46	80.PCIE-PCIE2.0_Slot(OPTION)
Page 47	90.Spdif TX/IR_RX
Page 48	92.Key/HW ID/LED
Page 49	93.Debug UART
Page 50	99.Mark/Hole/Heatsink
Page 51	
Page 52	
Page 53	

Generate Bill of Materials

Header:

Item\tPart\tDescription\tPCB Footprint\tReference\tQuantity\tOption

Combined property string:

{Item}\t{Value}\t{Description}\t{PCB Footprint}\t{Reference}\t{Quantity}\t{Option}

Description

Note

Option

Notes

NOTE 1:

Component parameter description

1. DNP stands for component not mounted temporarily
2. If Value or option is DNP, which means the area is reserved without being mounted

NOTE 2:

Please use our recommended components to avoid too many changes.
For more informations about the second source,please refer to our AVL.

Title	HT2	https://www.nas-ya.com/
Size	Document Number	Rev
X3	<Doc>	<Rev Code>
Date:	Friday, April 12, 2024	Sheet 2 of 23

RK3528_N (POWER)

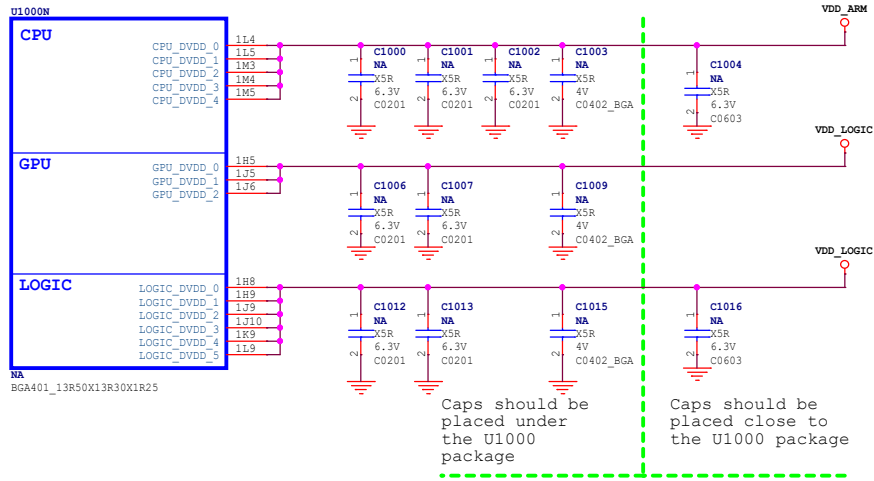

RK3528_O/P/Q (GND)

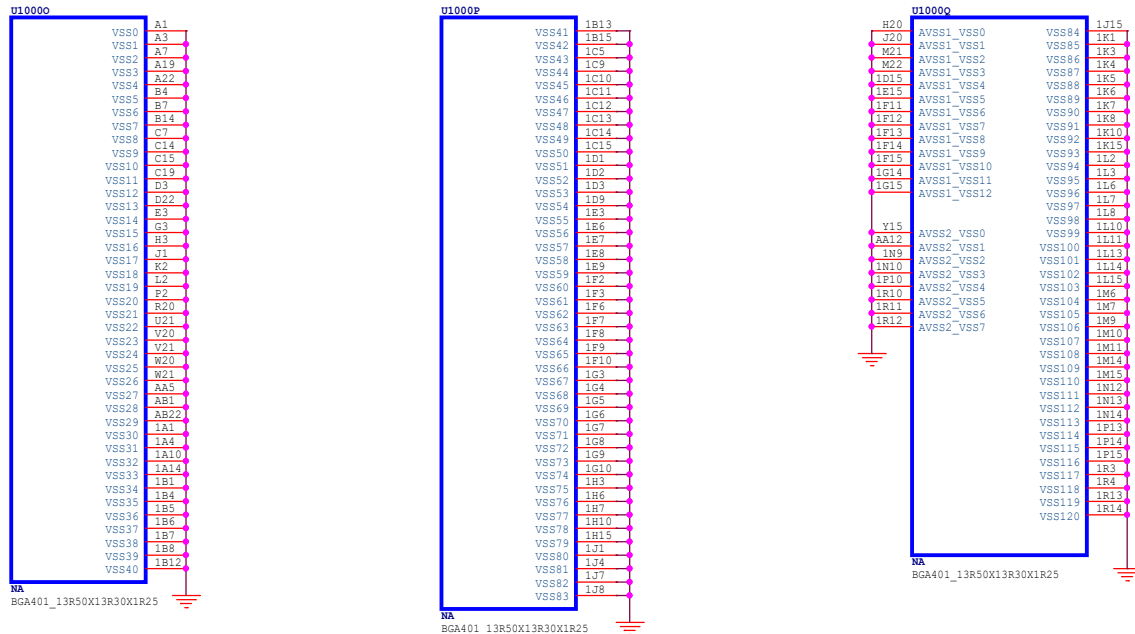

RK3528_B (OSC/PLL/PMUIO Domain)

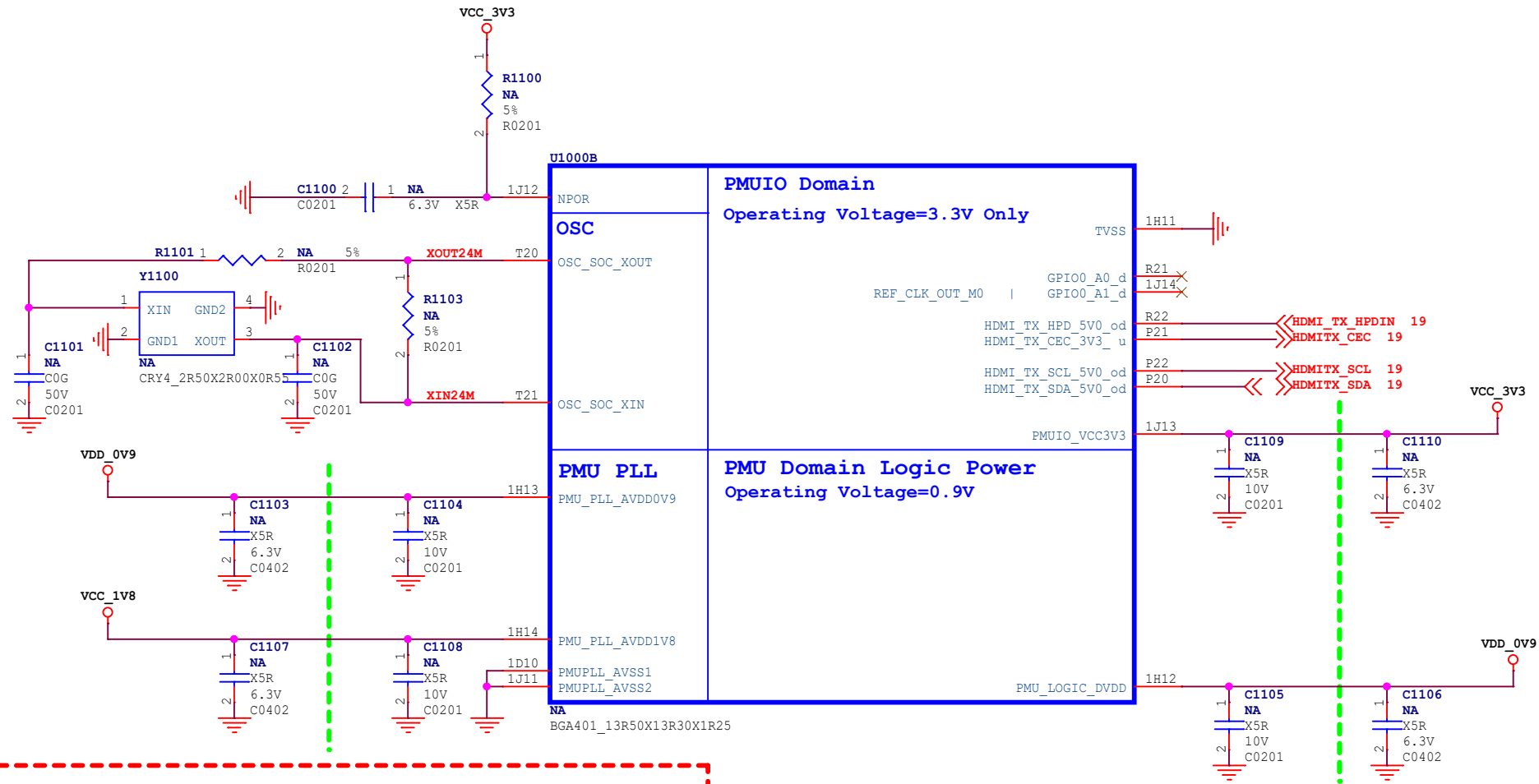

Note:
 Caps of between dashed green lines and U1000 should be placed under the U1000 package.
 Other caps should be placed close to the U1000 package

Title		
HT2		
Size	Document Number	Rev
A4	<Doc>	
Date:	Friday, April 12, 2024	Sheet 4 of 23

RK3528_E (VCCIO1 Domain)

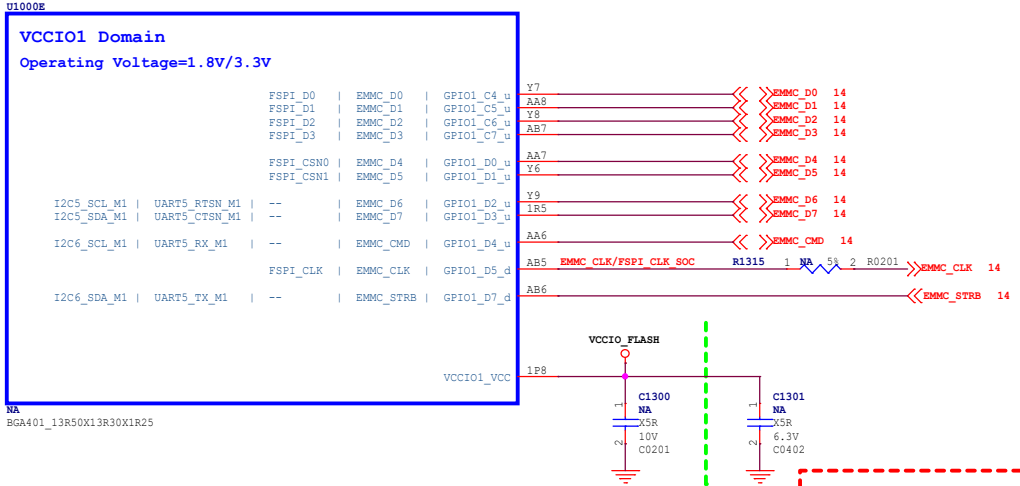

FSPI (Flexible Serial Peripheral Interface) is only used to connect SPI Flash/Memory devices. Do not use for connecting to other SPI devices

Default DiscretePower solution, power by VCC_1V8
 PMIC solution, power by VCC1V8_EMMC, only 1.8V

Note:
 Caps of between dashed green lines and U1000 should be placed under the U1000 package.
 Other caps should be placed close to the U1000 package

RK3528_F (VCCIO2 Domain)

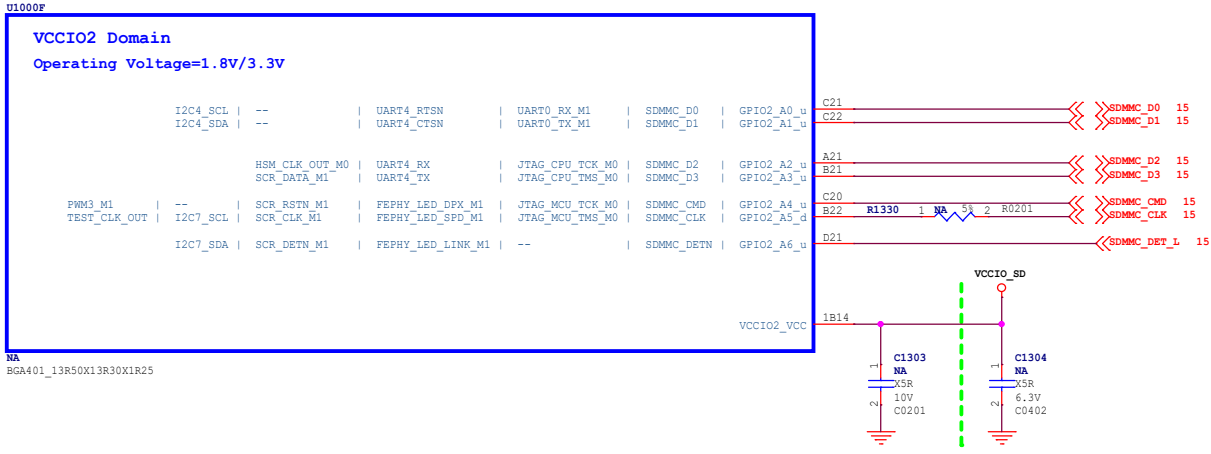

Note:
 Caps of between dashed green lines and U1000 should be placed under the U1000 package.
 Other caps should be placed close to the U1000 package

Title		
HT2		
Size	Document Number	Rev
A3	<Doc>	
Date:	Friday, April 12, 2024	Sheet 6 of 23

RK3528_I (USB2.0 OTG/HOST)

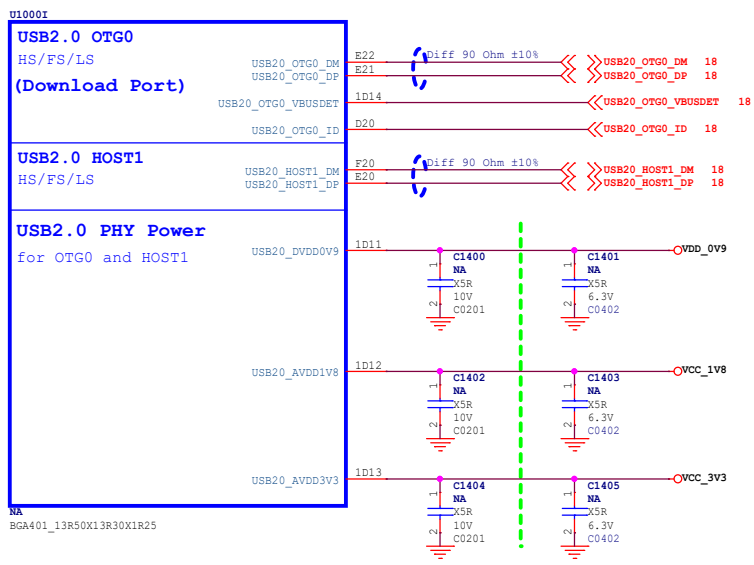

Note:
 Caps of between dashed green lines and U1000 should be placed under the U1000 package.
 Other caps should be placed close to the U1000 package

RK3528_J (PCIE2.0/U3 PHY)

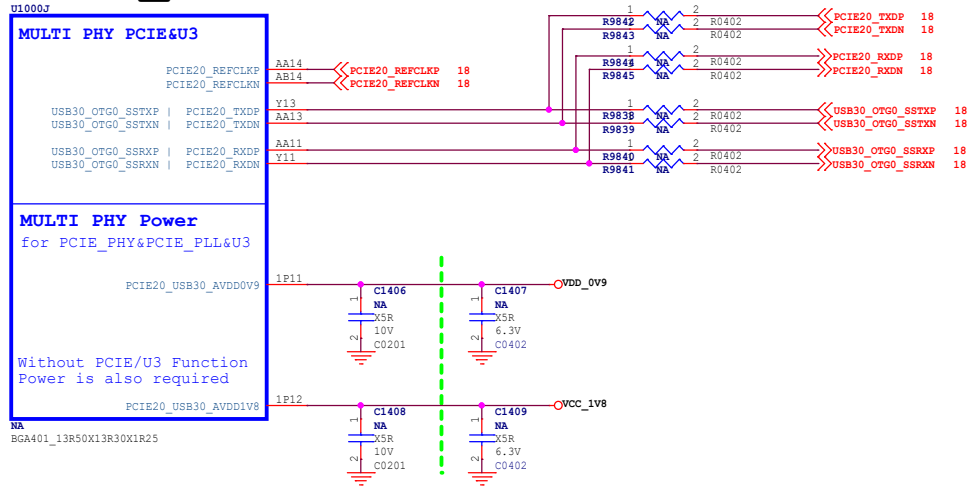

Note:
 Caps of between dashed green lines and U1000 should be placed under the U1000 package.
 Other caps should be placed close to the U1000 package

Title		HT2
Size	Document Number	Rev
A3	<Doc>	
Date:	Friday, April 12, 2024	Sheet 7 of 23

RK3528_C (Saradc/OTP)

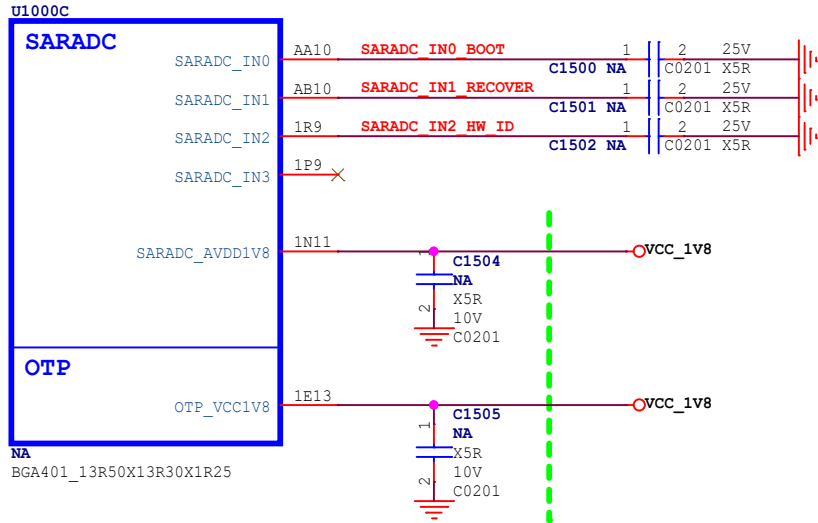

Note:

Caps of between dashed green lines and U1000 should be placed under the U1000 package. Other caps should be placed close to the U1000 package

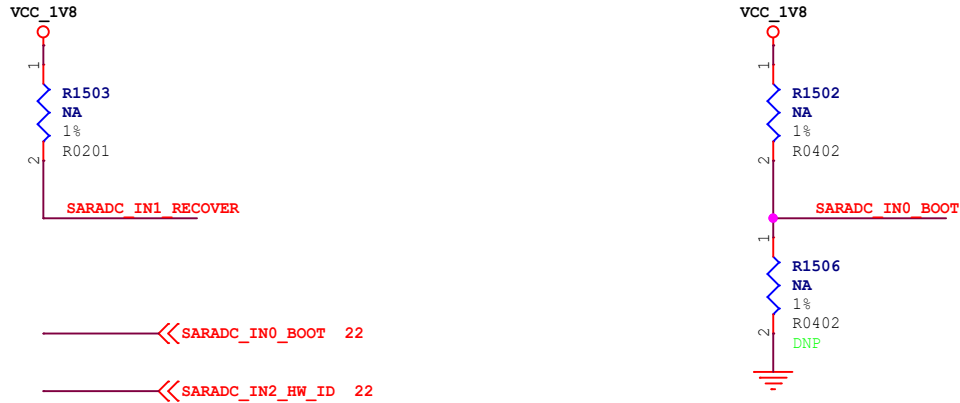

TABLE

Item	Rup	Rdown	ADC	BOOT MODE
LEVEL1	DNP	100K	0	USB (Maskrom mode)
LEVEL2	100K	12K	114	
LEVEL3	100K	27K	228	FSPI--USB
LEVEL4	100K	51K	342	
LEVEL5	100K	82K	456	
LEVEL6	100K	120K	570	EMMC--USB
LEVEL7	100K	200K	683	EMMC--SD Card--USB
LEVEL8	100K	330K	796	SD Card--USB
LEVEL9	100K	820K	910	
LEVEL10	100K	DNP	1023	FSPI--EMMC--SD Card--USB

Title		
HT2		
Size	Document Number	Rev
A4	<Doc>	
Date:	Friday, April 12, 2024	Sheet 8 of 23

RK3528_L (HDMI PHY)

U1000L

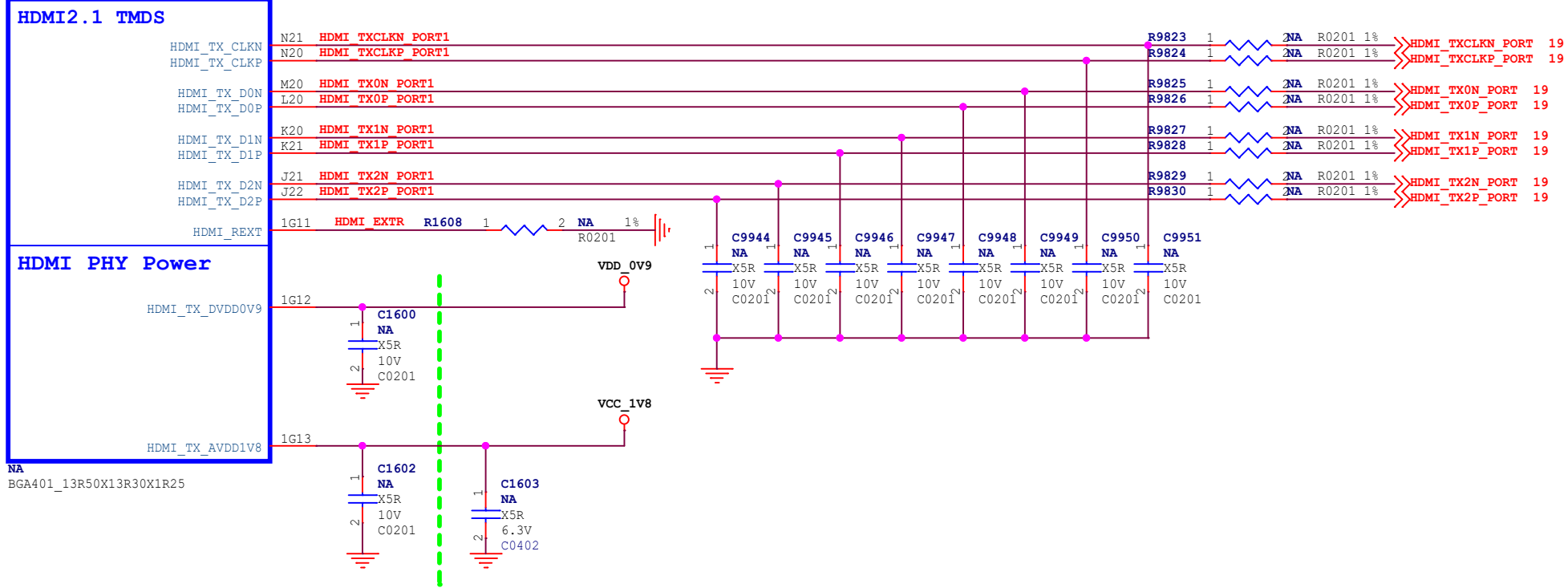

NA
BGA401_13R50X13R30X1R25

Note:
Caps of between dashed green lines and U1000 should be placed under the U1000 package.
Other caps should be placed close to the U1000 package

Title			HT2		
Size	Document Number				Rev
A4	<Doc>				
Date:	Friday, April 12, 2024		Sheet	9	of 23

RK3528_M (Acodec/VDAC)

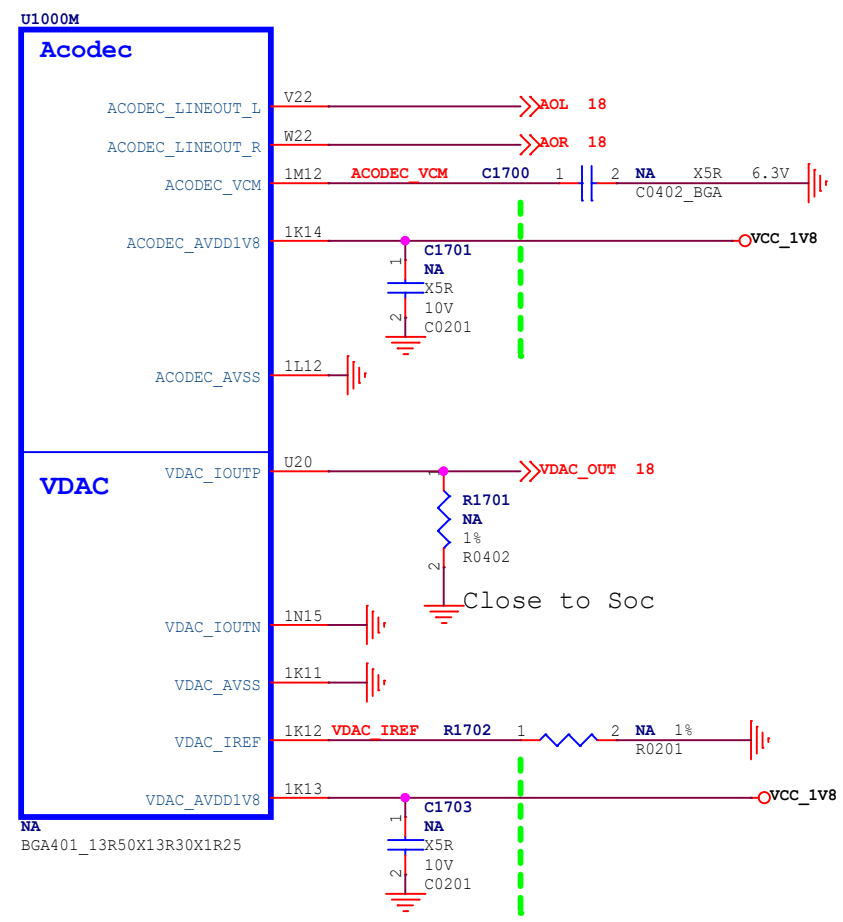

Note:
Caps of between dashed green lines and U1000 should be placed under the U1000 package. Other caps should be placed close to the U1000 package

Title		
HT2		
Size	Document Number	Rev
A4	<Doc>	
Date:	Friday, April 12, 2024	Sheet 10 of 23

RK3528_K (Embed FEPHY)

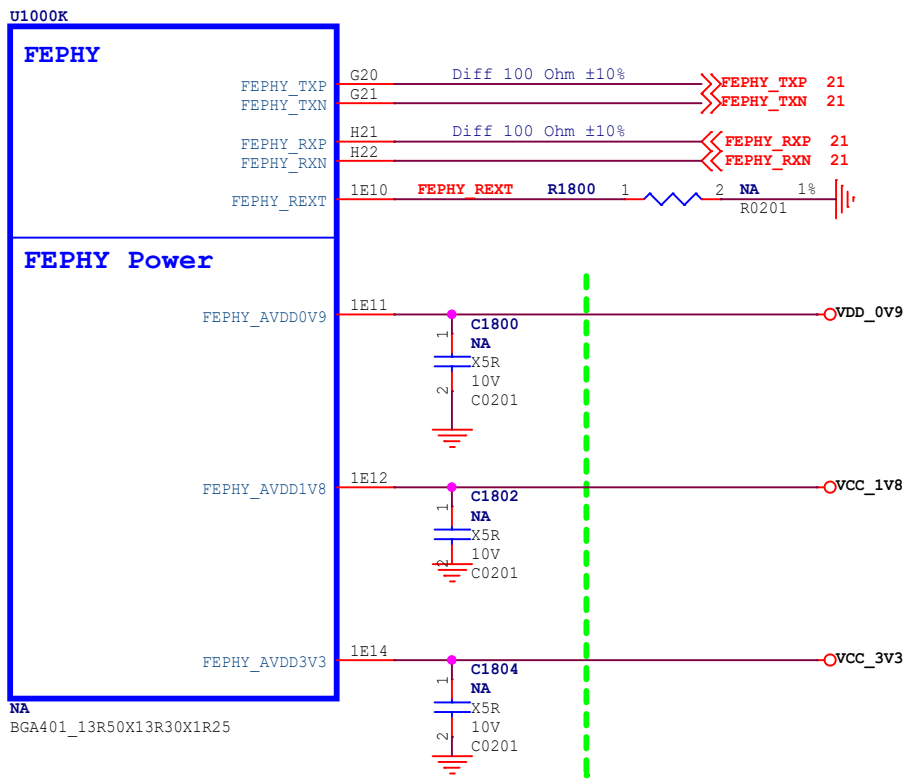

Note:
 Caps of between dashed green lines and U1000 should be placed under the U1000 package.
 Other caps should be placed close to the U1000 package

Title		
HT2		
Size	Document Number	Rev
A4	<Doc>	
Date:	Friday, April 12, 2024	Sheet 11 of 23

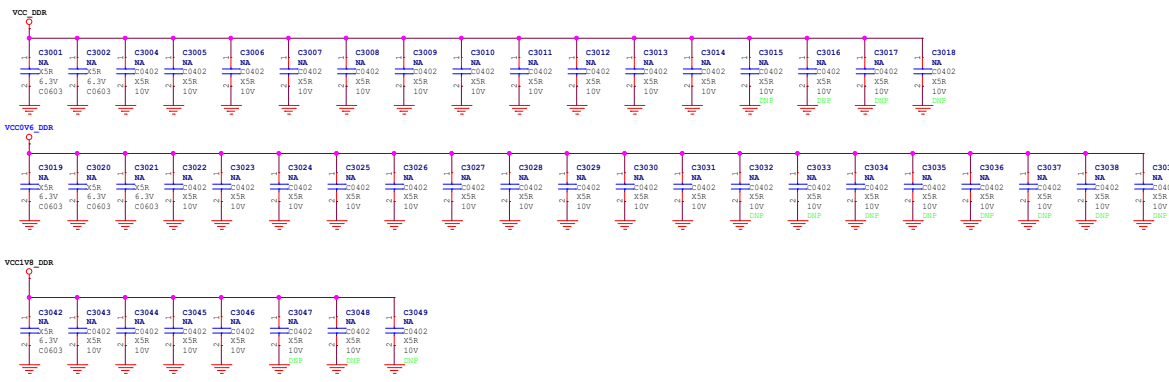
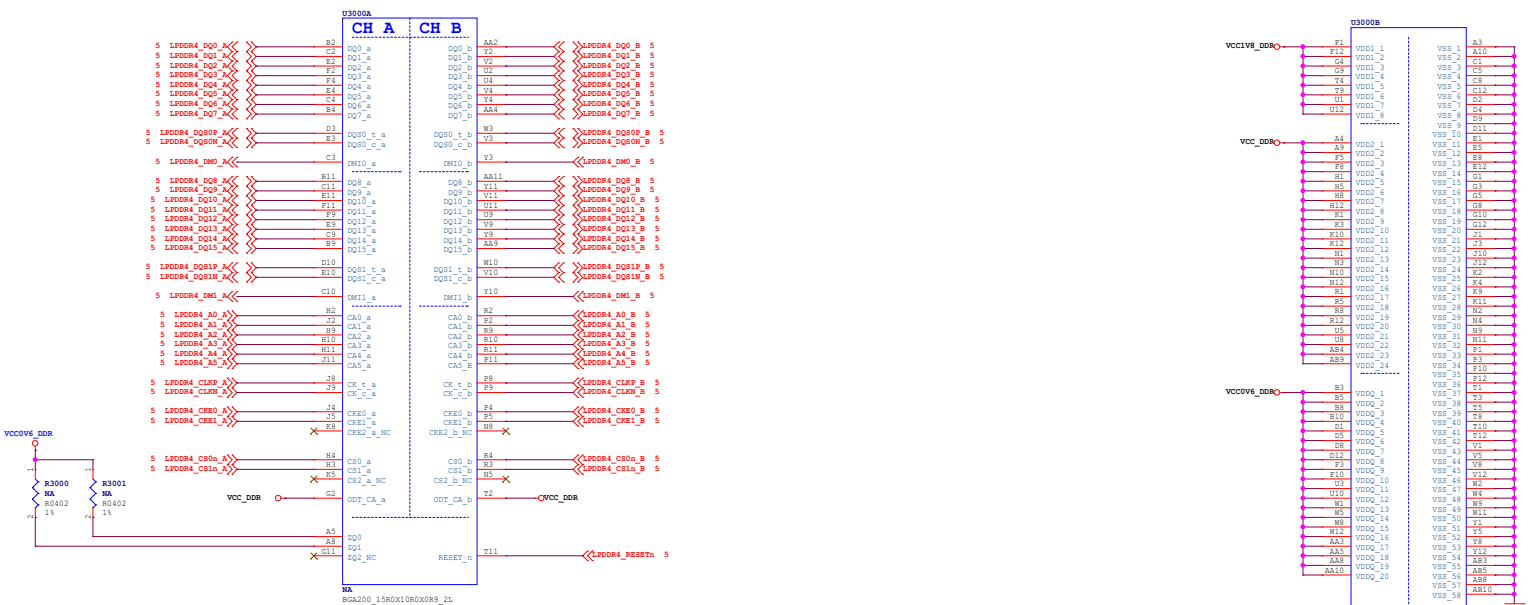

VCC0V6_DDR

VCC1V8_DDR

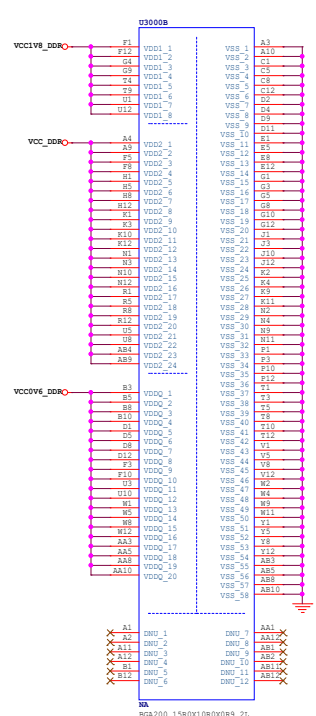
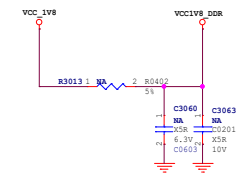
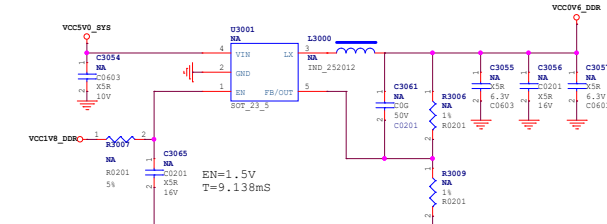

EMMC

FSPI

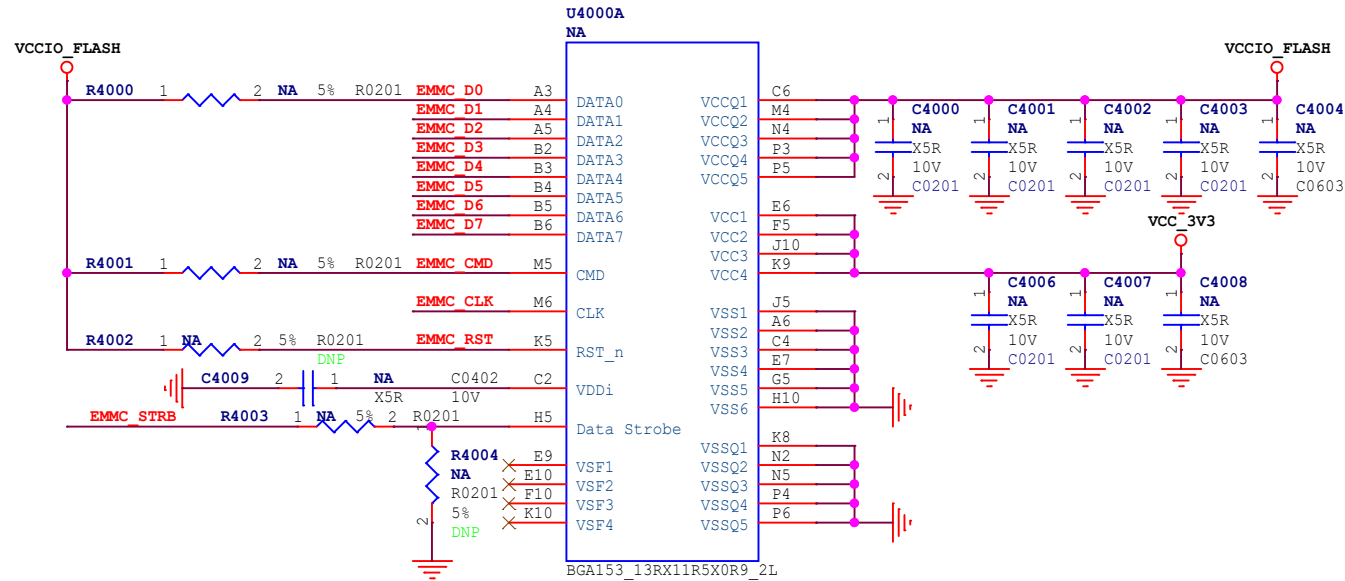
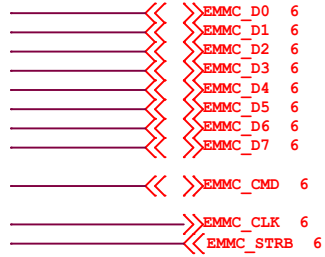

U4000B		A7	E5	E8	G3	G10	K6	K7	P7	P10	RF09
NA											
A2	NC2	RFU1	RFU2	RFU3	RFU4	RFU5	RFU6	RFU7	RFU8	RFU9	
A8	NC8										NC196
A9	NC9										NC195
A10	NC10										NC194
A11	NC11										NC193
A12	NC12										NC191
A13	NC13										NC190
A14	NC14										NC189
B1	NC15										NC188
B7	NC21										NC187
B8	NC22										NC186
B9	NC23										NC185
B10	NC24										NC184
B11	NC25										NC183
B12	NC26										NC182
B13	NC27										NC181
B14	NC28										NC180
C1	NC29										NC179
C3	NC31										NC178
C7	NC35										NC177
C8	NC36										NC176
C9	NC37										NC175
C10	NC38										NC174
C11	NC39										NC173
C12	NC40										NC172
C13	NC41										NC171
C14	NC42										NC170
D1	NC43										NC169
D2	NC44										NC168
D3	NC45										NC167
D4	NC46										NC166
D12	NC54										NC165
D13	NC55										NC164
D14	NC56										NC163
E1	NC57										NC162
E2	NC58										NC161
E3	NC59										NC160
E12	NC68										NC159
E13	NC69										NC158
E14	NC70										NC157
F1	NC71										NC156
F2	NC72										NC155
F3	NC73										NC154
F12	NC82										NC153
F13	NC83										NC152
F14	NC84										NC151
G1	NC85										NC150
G2	NC86										NC149
G12	NC96										NC148
G13	NC97										NC147
G14	NC98										NC146
											NC145
											NC144
											NC143
											NC142
											NC141
											NC140
											NC139
											NC138
											NC137
											NC136
											NC135
											NC134
											NC133
											NC132
											NC131
											NC130
											NC129
											NC128
											NC127
											NC126
											NC125
											NC124
											NC123
											NC122
											NC121
											NC120
											NC119
											NC118
											NC117
											NC116
											NC115
											NC114
											NC113
											NC112
											NC111
											NC110
											NC109
											NC108
											NC107
											NC106
											NC105
											NC104
											NC103
											NC102
											NC101
											NC100
											NC99

BGA153_13RX11R5X0R9_2L

Title			HT2		
Size	Document Number		Rev		
A4	<Doc>				
Date:	Friday, April 12, 2024		Sheet	14	of 23

TF Card

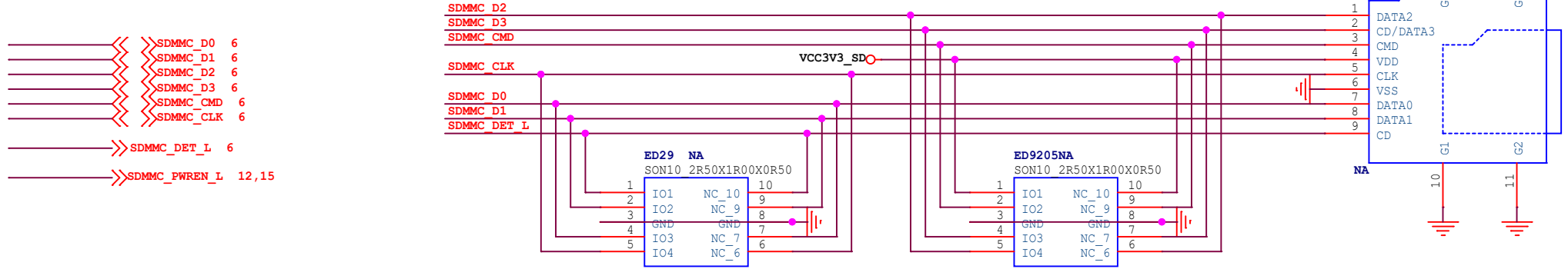

VCCIO_SD

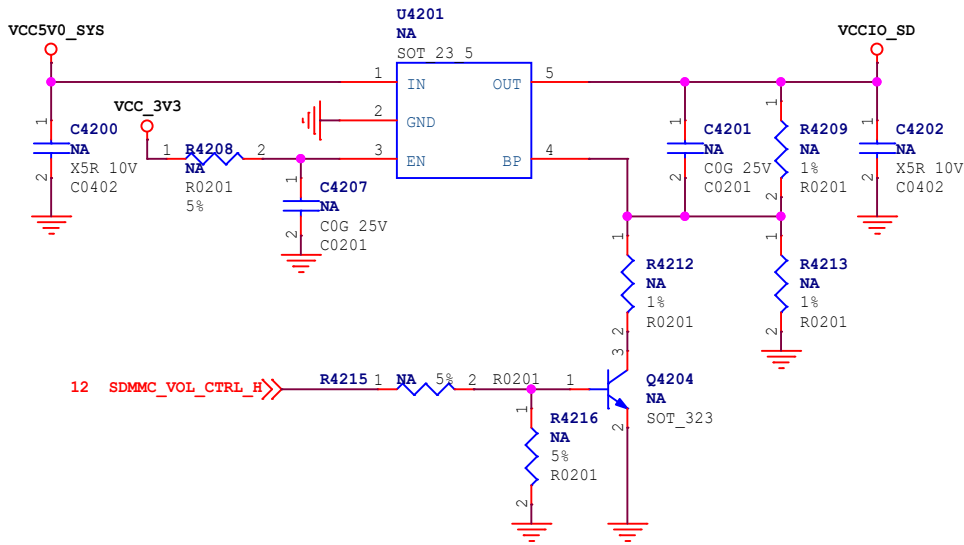

VCC3V3_SD

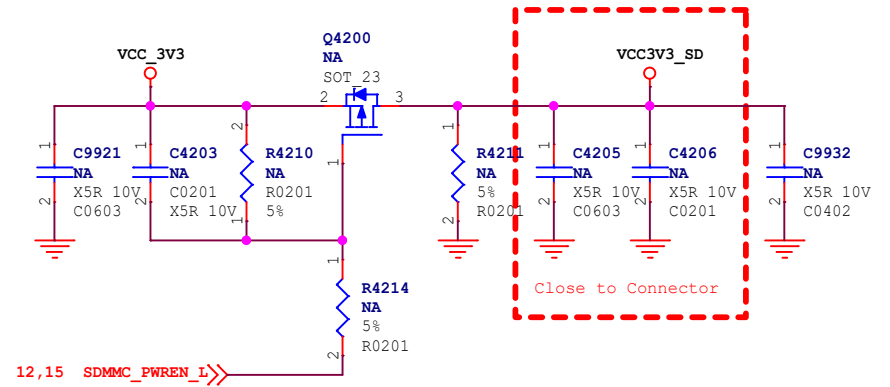

SDMMC_PWREN=L VCC_SD=3.3V(Default)
SDMMC_PWREN=H VCC_SD=0V

SDIO2.0 SDMMC0_VOL_CTRL=H VCCIO_SD=3.34V(Default)
SDIO3.0 SDMMC0_VOL_CTRL=L VCCIO_SD=1.816V

Title		
HT2		
Size	Document Number	Rev
A4	<Doc>	
Date:	Friday, April 12, 2024	Sheet 15 of 23

VCC5V0_SYS-->VDD_LOGIC

Step 1

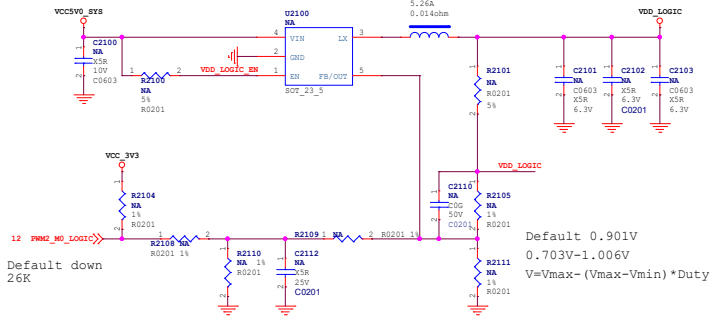

VCC5V0_SYS-->VDD_ARM

Step 1

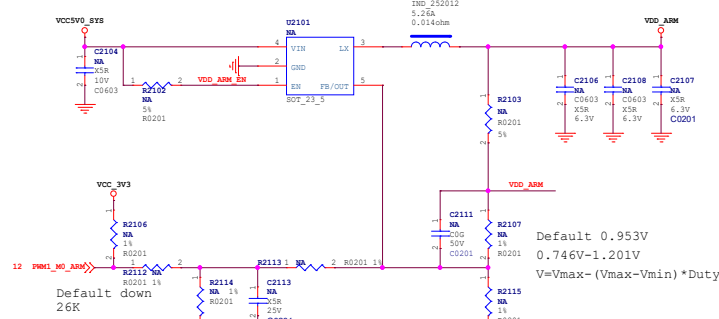

VCC5V0_SYS-->VDD_0V9

Step 1

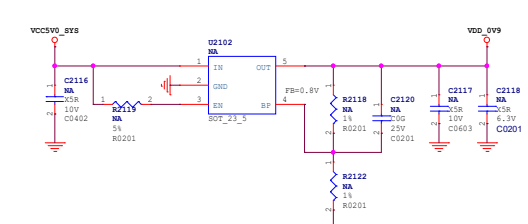

Note:
When LAYOUT, a star must be used,
Branch to each load

VCC5V0_SYS-->VCC_DDR

Step 2

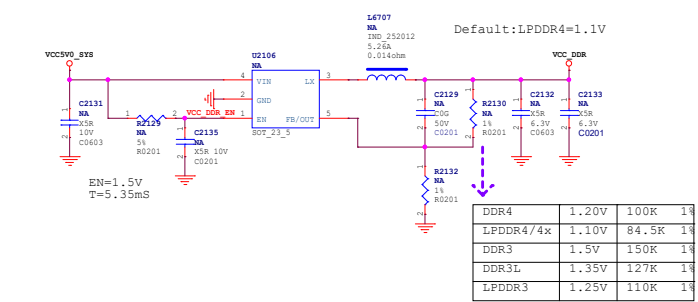

VCC_3V3->VCC_1V8(LDO)

Step 2

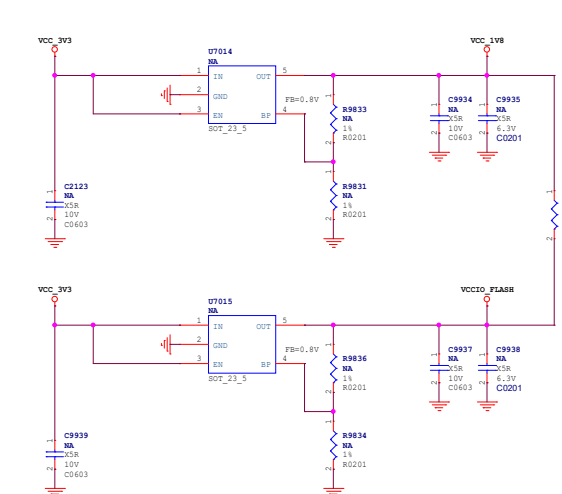

VCC5V0_SYS-->VCC_3V3

Step 2

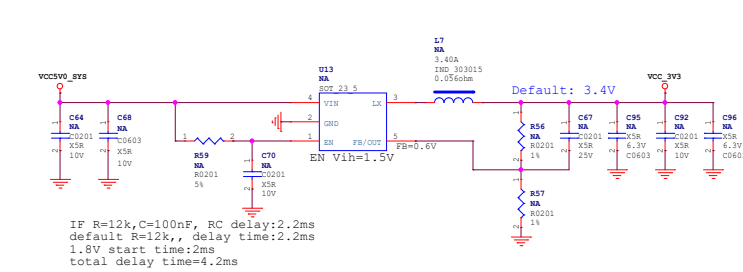

5V_SYS

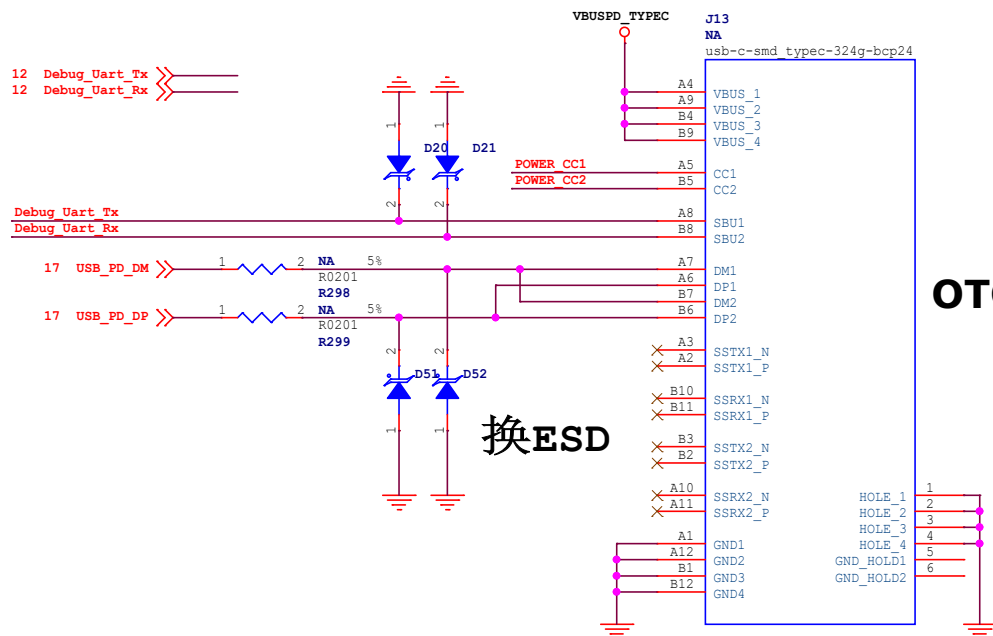
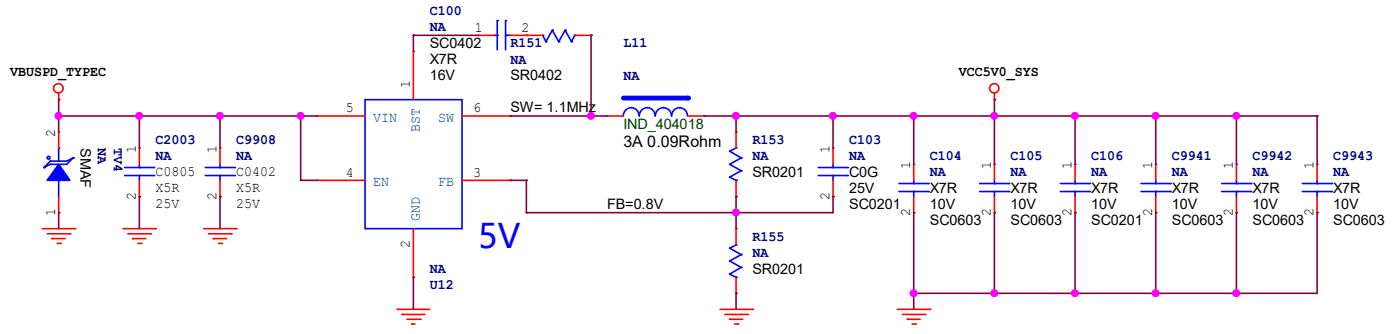

OTG USB+Debug

换ESD

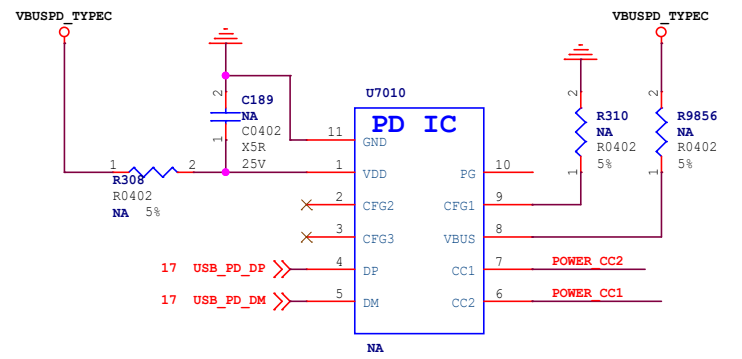

Title		
HT2		
Size	Document Number	Rev
Custom<Doc>		
Date:	Friday, April 12, 2024	Sheet 17 of 23

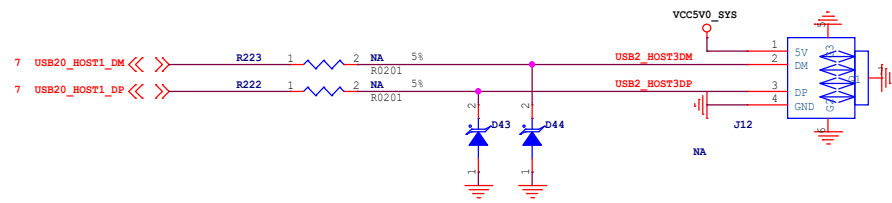

USB2.0 HOST1

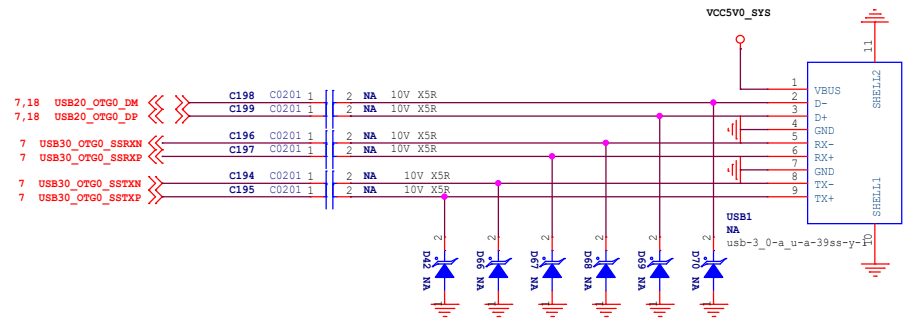
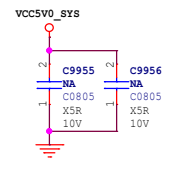

USB3.0 HOST1

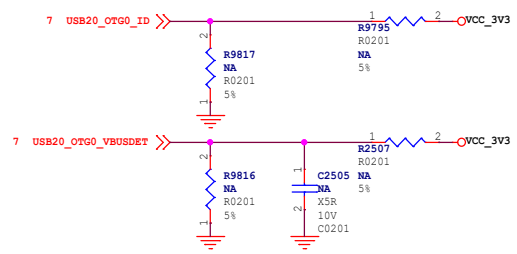
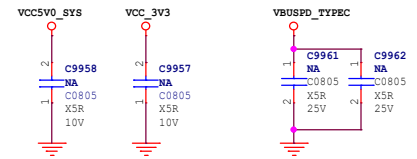
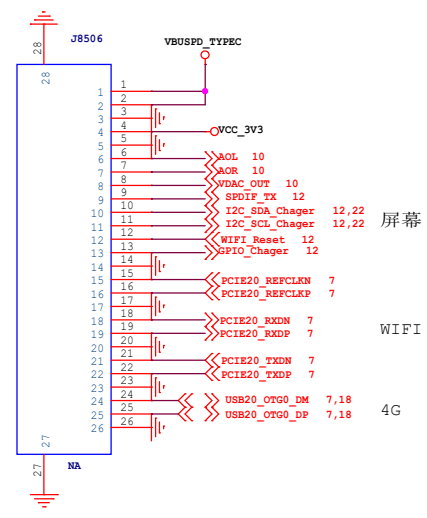
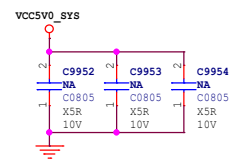

Title		
HT2		
Size	Document Number	Rev
A3	<Doc>	
Date:	Friday, April 12, 2024	Sheet 18 of 23

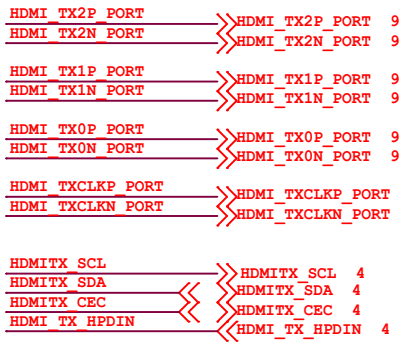

HDMI TX DDC

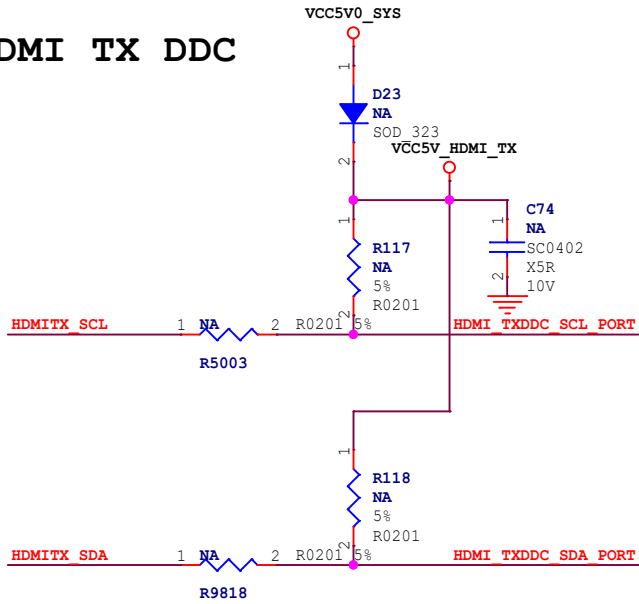

HDMI TX CEC



HDMI TX HPD

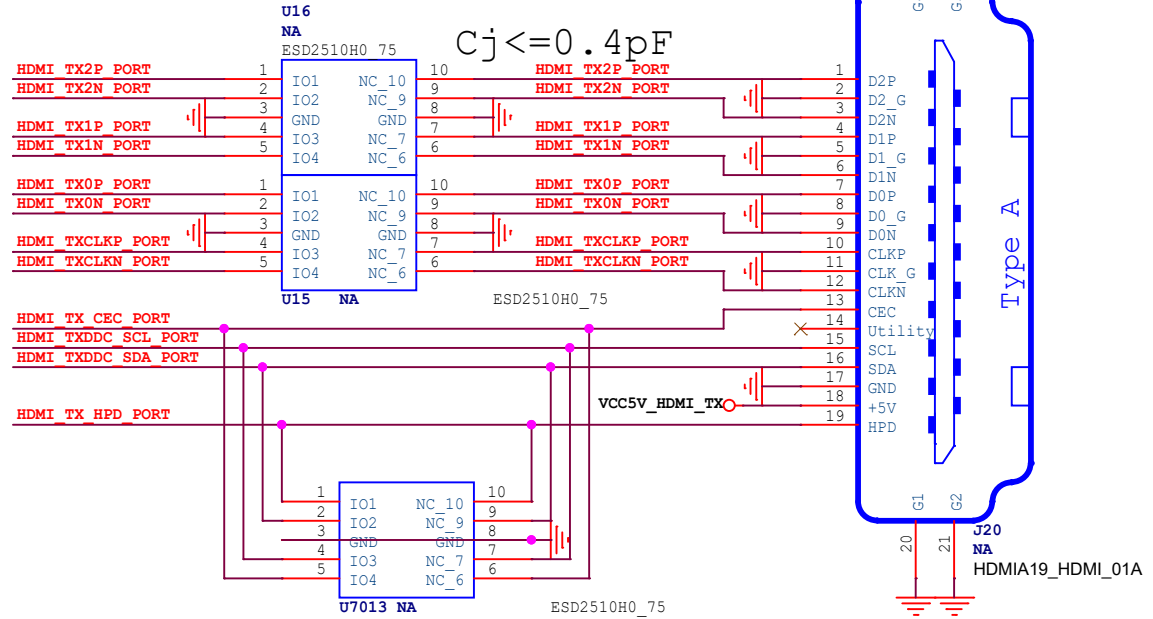
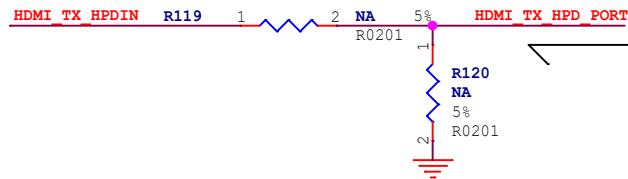

Title		HT2
Size	Document Number	Rev
A4	<Doc>	
Date:	Friday, April 12, 2024	Sheet 19 of 23

WIFI

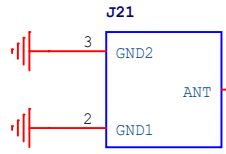
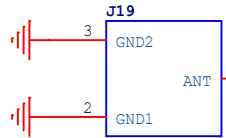

WIFI/BT

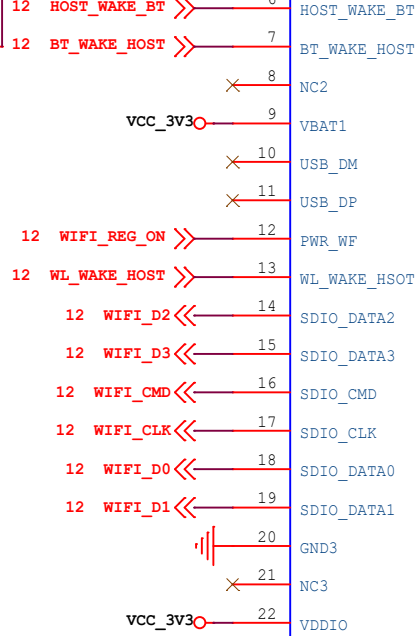

SKI.WB800D80S.1

NA
U7012

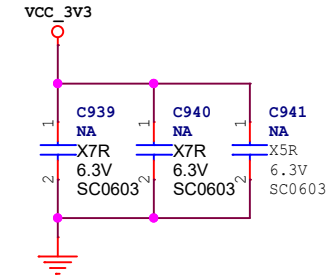
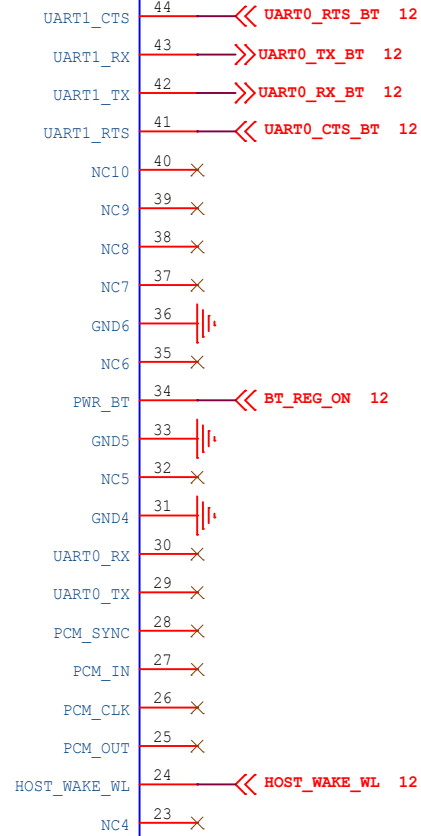

Title		
HT2		
Size	Document Number	Rev
A4	<Doc>	
Date:	Friday, April 12, 2024	Sheet 20 of 23

RGMI I

- >>> GMAC1_TXD0 12
- >>> GMAC1_TXD1 12
- >>> GMAC1_TXD2 12
- >>> GMAC1_TXD3 12
- >>> GMAC1_TXEN 12
- >>> GMAC1_TXCLK 12
- >>> GMAC1_RXD0 12
- >>> GMAC1_RXD1 12
- >>> GMAC1_RXD2 12
- >>> GMAC1_RXD3 12
- >>> GMAC1_RXDV_CRS 12
- >>> GMAC1_RXCLK 12
- >>> GMAC1_MCLKINOUT 12
- >>> GMAC1_MDC 12
- >>> GMAC1_MDIO 12
- >>> GMAC1_RSTn_L 12

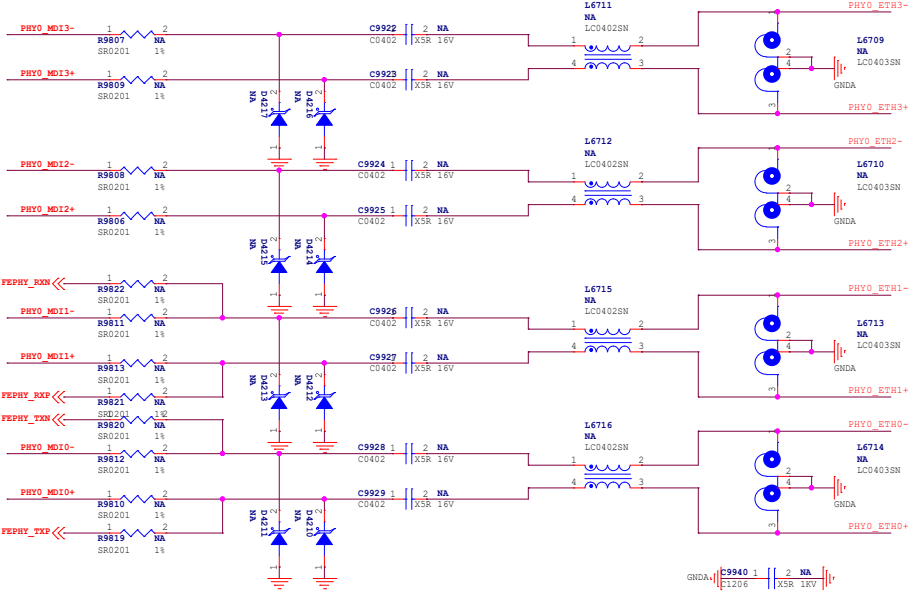
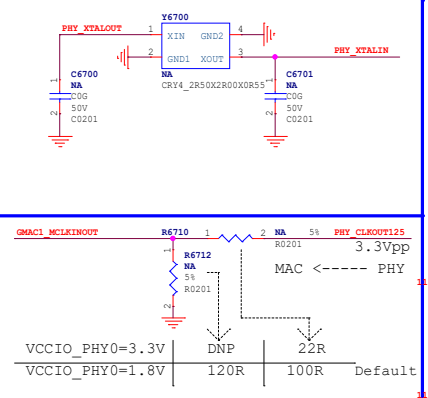

- PHY0_ETH0+ 1
- PHY0_ETH0- 2
- PHY0_ETH1+ 3
- PHY0_ETH1- 4
- PHY0_ETH2+ 5
- PHY0_ETH2- 6
- PHY0_ETH3+ 7
- PHY0_ETH3- 8

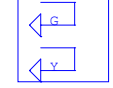

默认不带灯

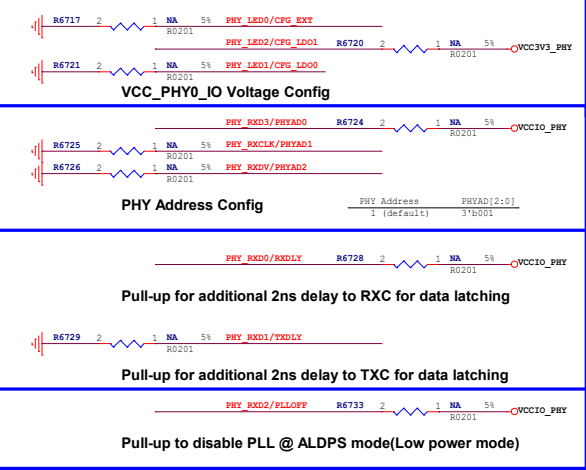
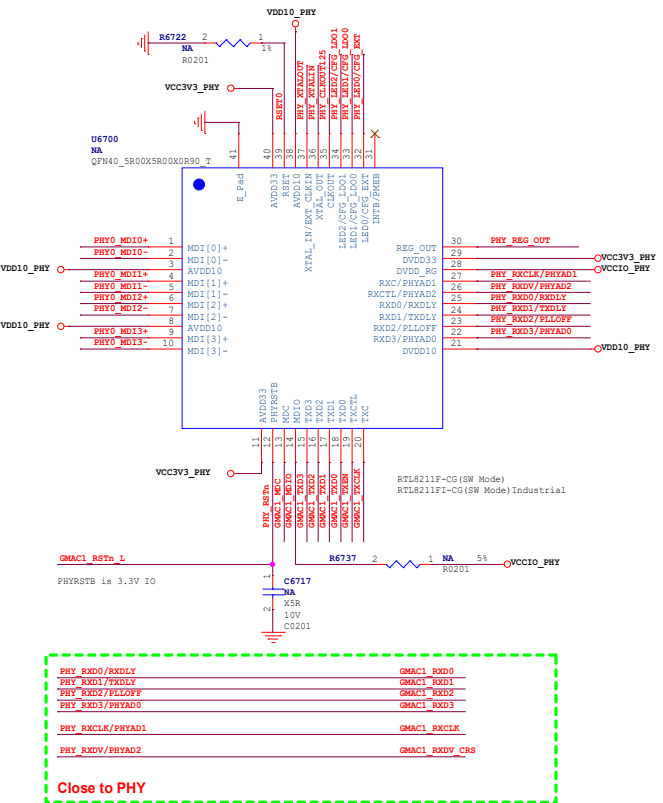

ROM1 Power Source	CFG EX1	CFG LDD[1:0]
External 3.3V	1'b1	2'b00
External 1.8V	1'b1	2'b10
Internal 1.8V(default)	1'b0	2'b10

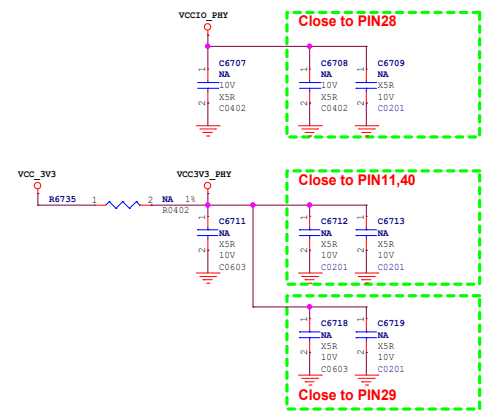
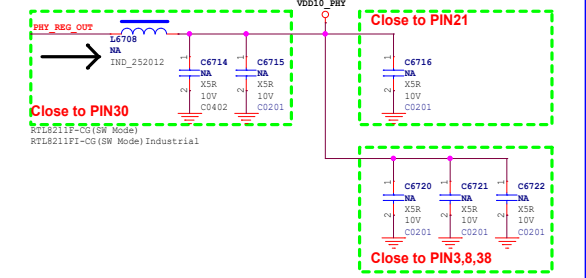

Title	RT2	
Size	Document Number	Rev
Date	Customer<Doc>	
	Friday, April 12, 2024	Sheet 21 of 23

KEY

SARADC_IN0_BOOT 8
SARADC_IN2_HW_ID 8

IR Receiver

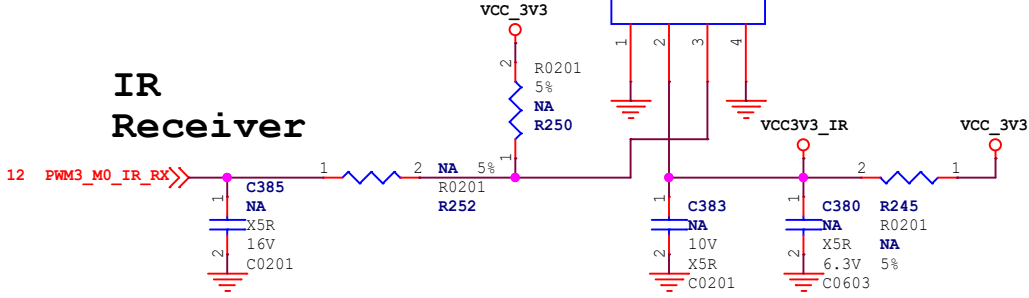

HW_ID

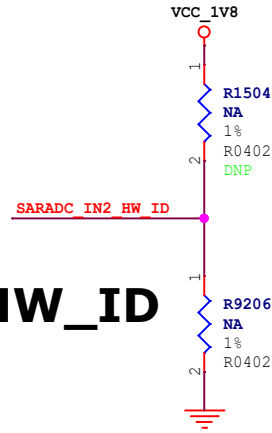

V1.0 TABLE

SARADC_IN2	Rup	Rdown	ADC
HW_ID0	DNP	100K	0
HW_ID1	100K	12K	114
HW_ID2	100K	27K	228
HW_ID3	100K	51K	342
HW_ID4	100K	82K	456
HW_ID5	100K	120K	570
HW_ID6	100K	200K	683
HW_ID7	100K	330K	796
HW_ID8	100K	820K	910
HW_ID9	100K	DNP	1023

POWER_LED

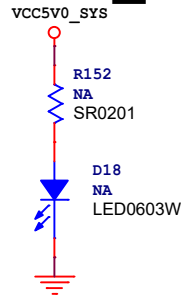

WORK_LED

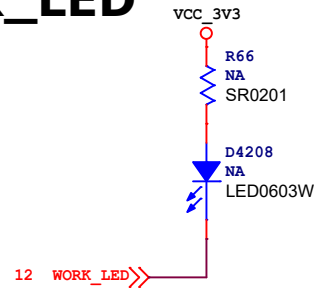

WAN_LED

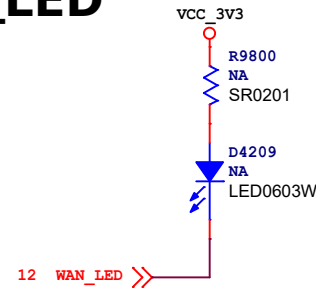

Title			HT2
Size	Document Number		Rev
A4	<Doc>		
Date:	Friday, April 12, 2024	Sheet	22 of 23

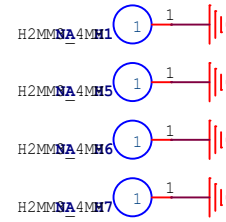

MARK4
NA



MARK2
NA



MARK1
NA



MARK3
NA

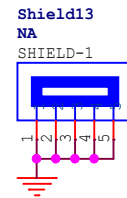
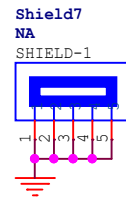
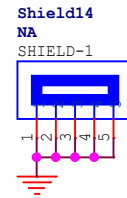
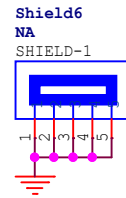

Title		
HT2		
Size	Document Number	Rev
A4	<Doc>	
Date:	Friday, April 12, 2024	Sheet 23 of 23