

Reference Schematics For RK3528

RK3528_BOX_REF_SCH_V10

Main Functions Introduction

- 1) Power: DiscretePower:BUCK+LDO or PMIC RK805-6
- 2) RAM: DDR3 4x16bit
DDR4 2x16Bit
DDR4 4x16Bit
LPDDR3 1x32bit
LPDDR4/LPDDR4X 1x32bit
- 3) ROM: eMMC5.1 or FSPI Flash
- 4) Support: Micro SD Card3.0
- 5) Support: 1 x USB3.0 OTG + 1 x USB2.0 HOST
- 6) Support: 1 x HDMI2.0 TX
- 7) Support: 1 x AV OUT
- 8) Support: SDIO WiFi5 + UART/PCM BT
PCIE WIFI5 + UART/PCM BT
- 9) Support: 1 x Ethernet(Embed PHY) + 1x Ethernet(RGMII or RMII)
- 10) Support: Optical S/PDIF TX
- 11) Support: IR Receiver
- 12) Support: Audio-MicArray 2xI2S-DMIC or 4xPDM-DMIC
- 13) Support: RECOVER/RESET/SARADC_BOOT_KEY,HW_ID
- 14) Support: 1 x PCIE2.0 Slot
- 15) Support: Debug UART

HINLINK

Project:	RK3528_H29K	 HINLINK
File:	00.Cover Page	
Date:	Saturday, November 23, 2024	Rev: <Revision>
Designer:	<designer>	Sheet: 1 of 26

Table of Content

Page 1	00.Cover Page
Page 2	01.Index and Notes
Page 3	02.Revision History
Page 4	03.Block Diagram
Page 5	04.Power Tree-DiscretePower
Page 6	04.Power Tree-PMIC RK805-6
Page 7	05.Power Sequence-DiscretePower
Page 8	05.Power Sequence-PMIC RK805-6
Page 9	06.UART Map
Page 10	07.I2C Bus Map
Page 11	08.USB3/PCIE Fun Map
Page 12	10.RK3528 Power/GND
Page 13	11.RK3528 OSC/PLL/PMUIO
Page 14	12.RK3528 DDR Controller
Page 15	13.RK3528 FLASH/SD Controller
Page 16	14.RK3528 USB/PCIE Controller
Page 17	15.RK3528 SARADC/OTP
Page 18	16.RK3528 HDMI Interface
Page 19	17.RK3528 AV OUT
Page 20	18.RK3528 Embed FEPHY
Page 21	19.RK3528_1.8V/3.3V GPIO
Page 22	20.Power-DCIN
Page 23	21.Power-DiscretePower
Page 24	22.Power-PMIC-RK805-6(OPTION)
Page 25	25.USB2/USB3 Port
Page 26	30.DRAM DDR3 4x16bit_96P
Page 27	30.DRAM-DDR4_2x16Bit_96P
Page 28	30.DRAM-DDR4_4x16Bit_96P
Page 29	30.DRAM-LPDDR3_1X32bit_178P
Page 30	30.DRAM-LPDDR4_1X32bit_200P
Page 31	30.DRAM-LPDDR4X_1X32bit_200P
Page 32	40.Flash-eMMC
Page 33	42.Flash-Micro-SD Card
Page 34	43.Flash-SPI FLASH(Option)
Page 35	50.VO-HDMI TX
Page 36	51.VO-AV Interface
Page 37	61.WIF/BT-SDIO_2T2R_AP6275S
Page 38	62.WIF/BT-SDIO_2T2R_RTL8822CS
Page 39	63.WIFI6/BT-PCIe_2T2R_AP6275P
Page 40	65.10/100M-Embed PHY
Page 41	66.Ethernet-FEPHY_RMII
Page 42	67.Ethernet-GEPHY_RGMII
Page 43	76.Audio-Headphone/MICIN
Page 44	77.Audio-MicArray(2xI2S-DMIC)
Page 45	78.Audio-MicArray(4xPDM-DMIC)
Page 46	80.PCIE-PCIE2.0_Slot(OPTION)
Page 47	90.Spdif TX/IR_RX
Page 48	92.Key/HW ID/LED
Page 49	93.Debug UART
Page 50	99.Mark/Hole/Heatsink
Page 51	
Page 52	
Page 53	

Generate Bill of Materials

Header:

Item\tPart\tDescription\tPCB Footprint\tReference\tQuantity\tOption

Combined property string:

{Item}\t{Value}\t{Description}\t{PCB Footprint}\t{Reference}\t{Quantity}\t{Option}

Description

Note

Option

Notes

NOTE 1:

Component parameter description

1. DNP stands for component not mounted temporarily
2. If Value or option is DNP, which means the area is reserved without being mounted

NOTE 2:

Please use our recommended components to avoid too many changes.
For more informations about the second source,please refer to our AVL.

HINLINK

Project:	RK3528_H29K	 HINLINK	
File:	01.Index and Notes		
Date:	Saturday, November 23, 2024	Rev:	<Revision>
Designer:	<designer>	Sheet:	2 of 26

RK3528_N (POWER)

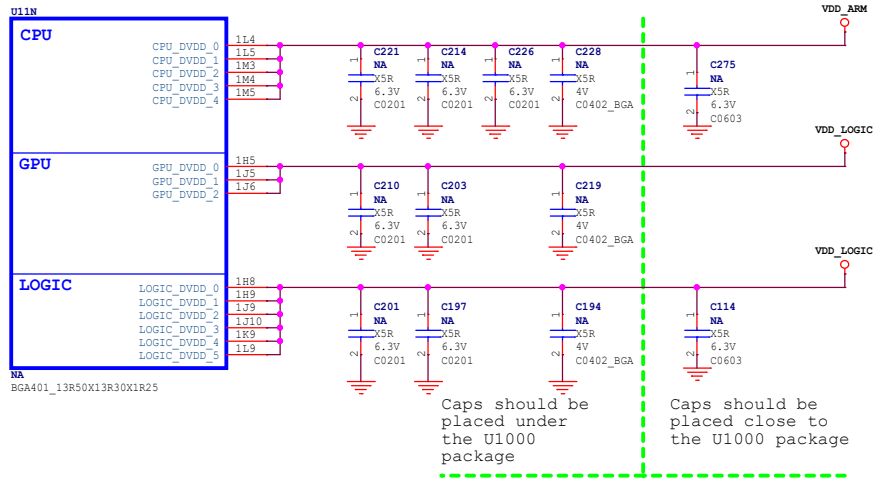

Note:
Caps of between dashed green lines and U1000 should be placed under the U1000 package.
Other caps should be placed close to the U1000 package

RK3528_O/P/Q (GND)

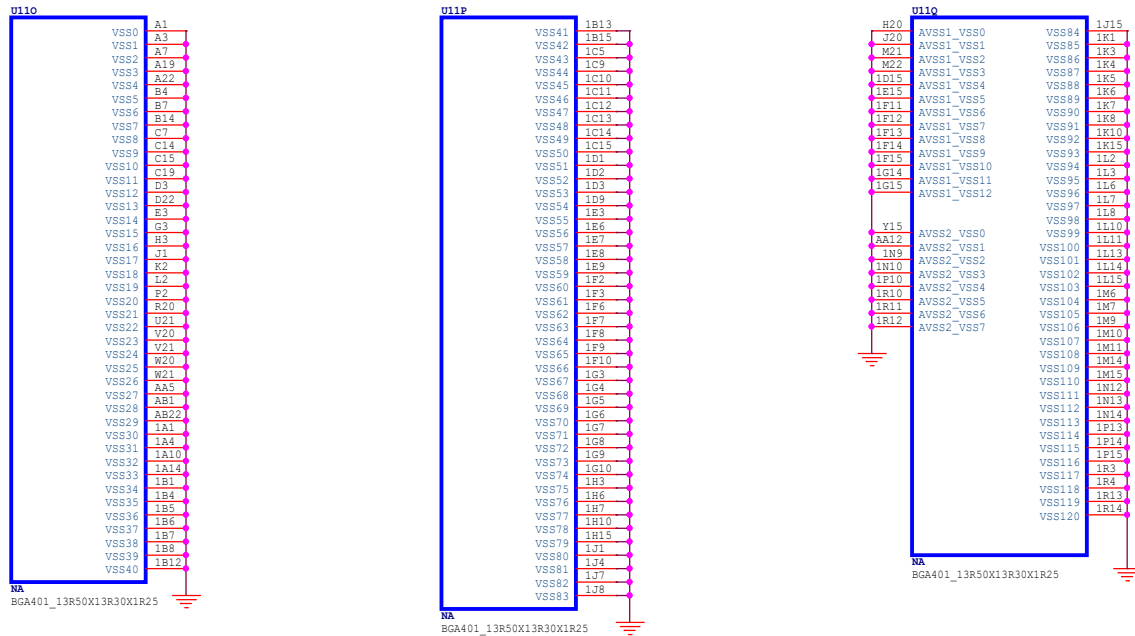

RK3528_B (OSC/PLL/PMUIO Domain)

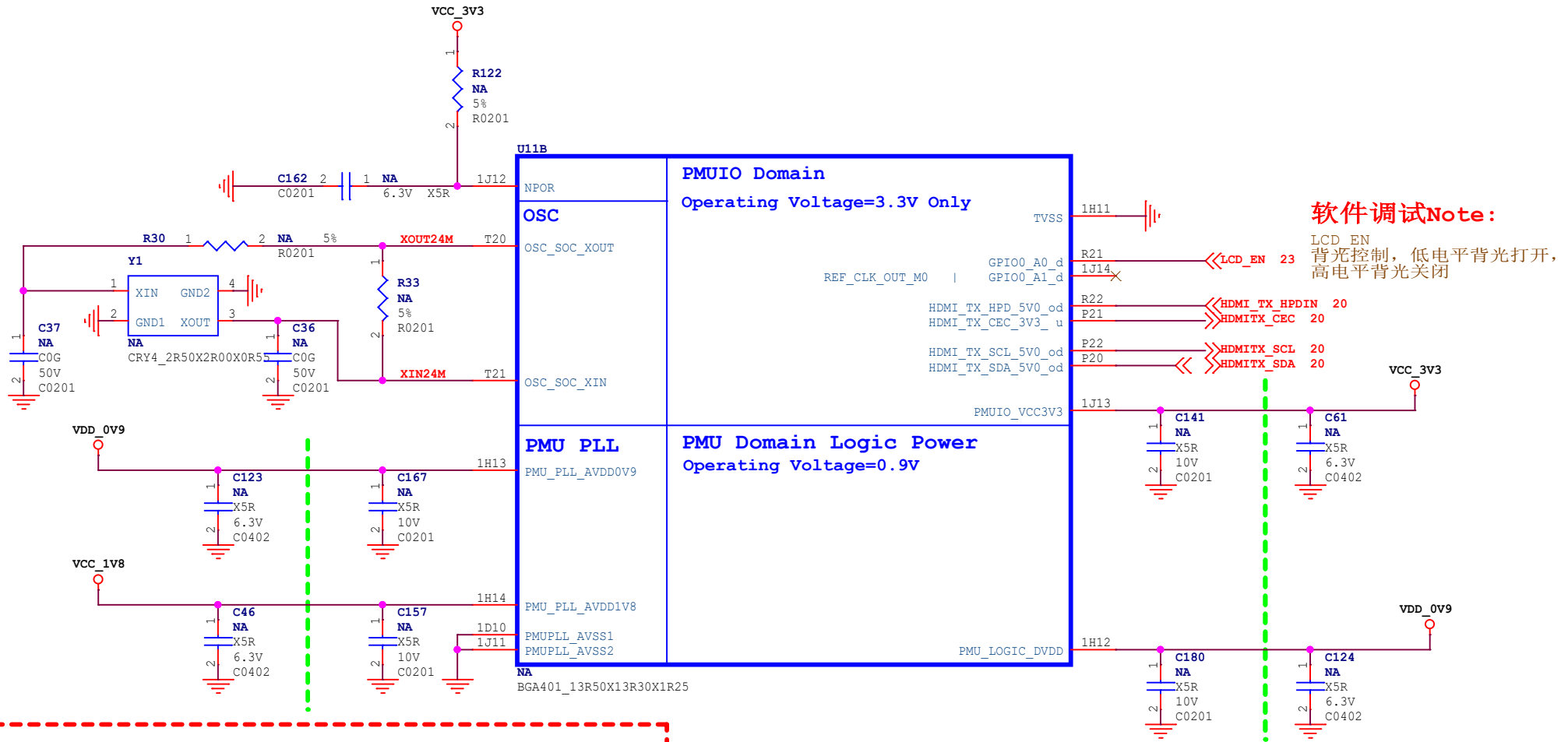

Note:
Caps of between dashed green lines and U1000 should be placed under the U1000 package.
Other caps should be placed close to the U1000 package

HINLINK		
Project:	RK3528_H29K	
File:	03.RK3528 OSC/PLL/PMUIO	
Date:	Saturday, November 23, 2024	Rev: <Revision>
Designer:	<designer>	Sheet: 4 of 26

RK3528_E (VCCIO1 Domain)

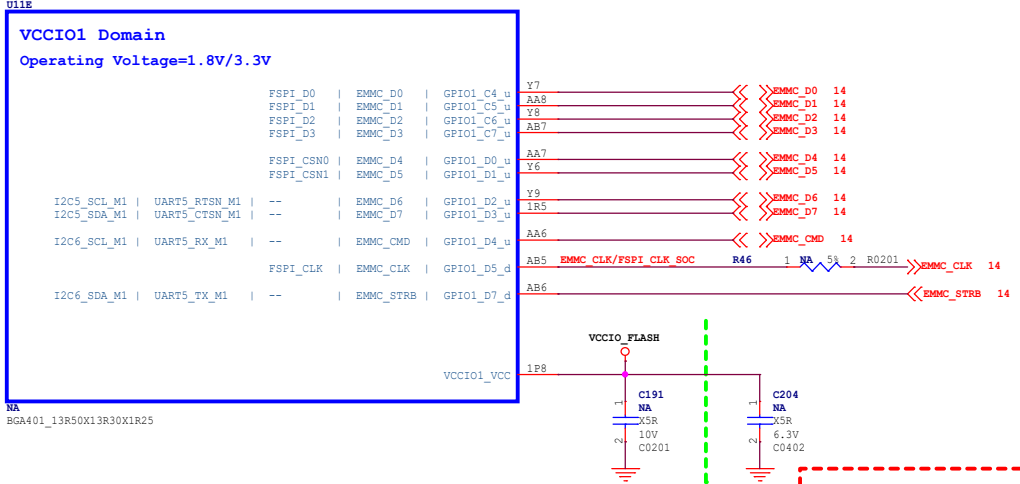

FSPI (Flexible Serial Peripheral Interface) is only used to connect SPI Flash/Memory devices. Do not use for connecting to other SPI devices.

Default DiscretePower solution, power by VCC_1V8
PMIC solution, power by VCC1V8_EMMC, only 1.8V

Note:
Caps of between dashed green lines and U1000 should be placed under the U1000 package. Other caps should be placed close to the U1000 package

RK3528_F (VCCIO2 Domain)

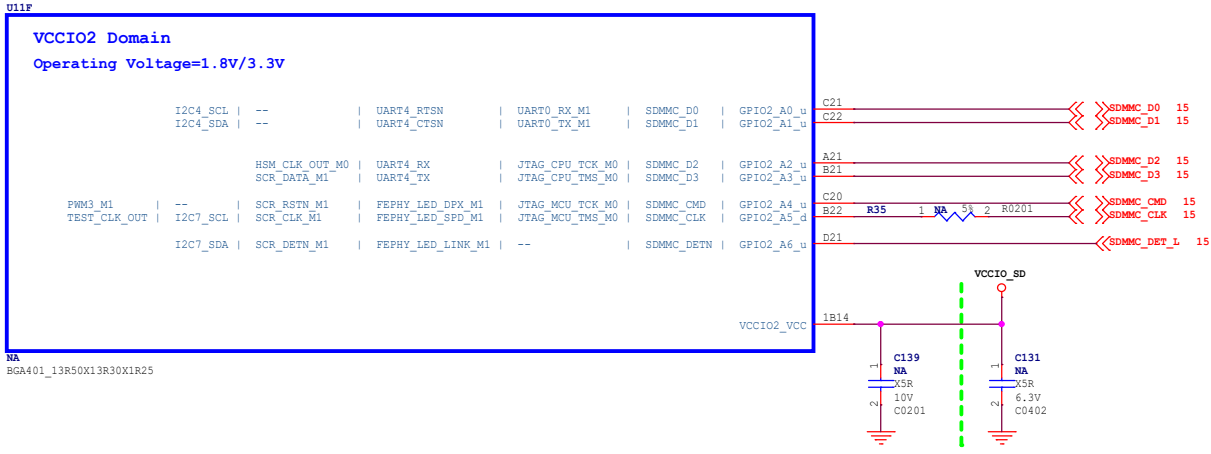

Note:
Caps of between dashed green lines and U1000 should be placed under the U1000 package. Other caps should be placed close to the U1000 package

HINLINK			
Project:	RK3528_H29K	Rev:	<Revision>
File:	05.RK3528 FLASH/SD Controller	Rev:	<Revision>
Date:	Saturday, November 23, 2024	Rev:	<Revision>
Designer:	<designer>	Sheet:	6 of 26

RK3528_I (USB2.0 OTG/HOST)

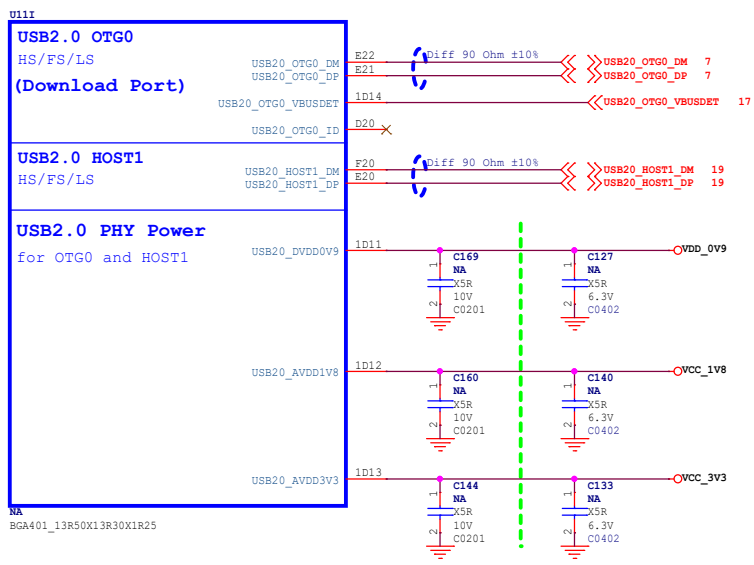

Note:
 Caps between dashed green lines and U1000 should be placed under the U1000 package.
 Other caps should be placed close to the U1000 package

RK3528_J (PCIE2.0/U3 PHY)

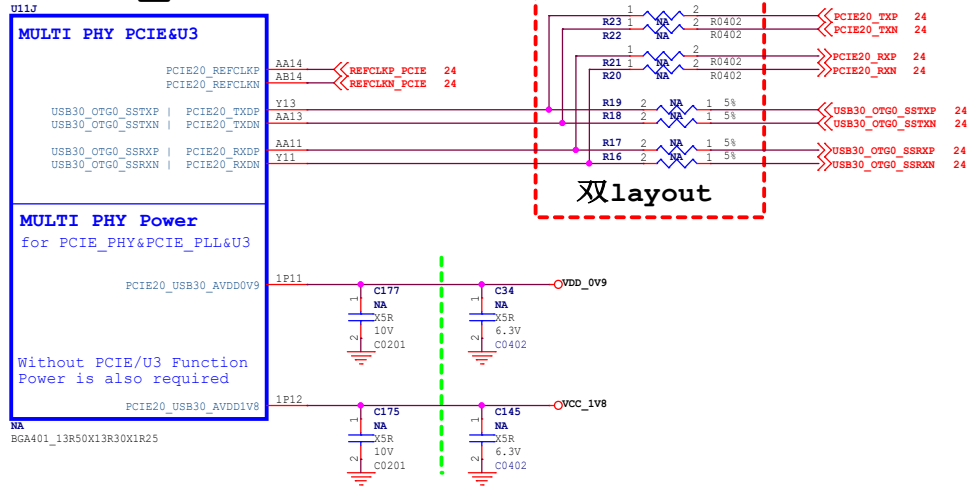

Note:
 Caps between dashed green lines and U1000 should be placed under the U1000 package.
 Other caps should be placed close to the U1000 package

HINLINK			
Project:	RK3528_H29K		HINLINK
File:	06.RK3528 USB/PCIE Controller		
Date:	Tuesday, January 07, 2025	Rev:	<Revision>
Designer:	<designer>	Sheet:	7 of 26

RK3528_C (Saradc/OTP)

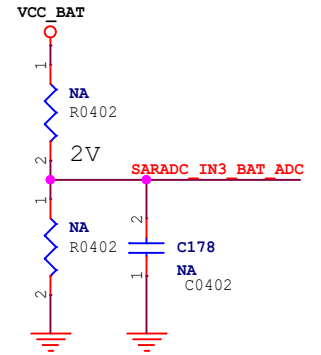
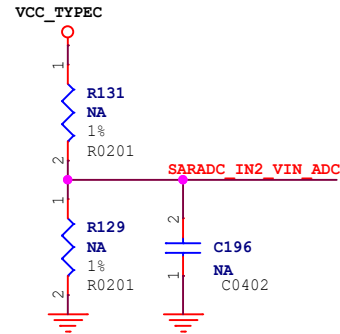
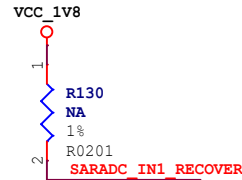
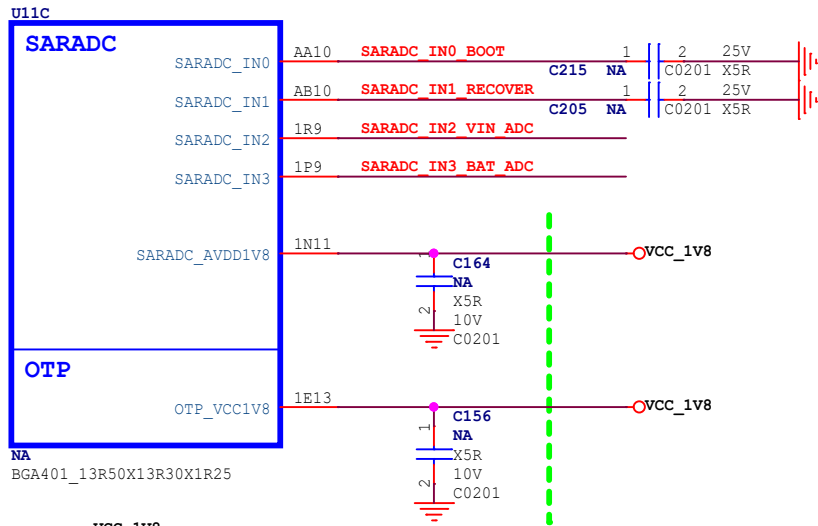

← SARADC_IN0_BOOT 7

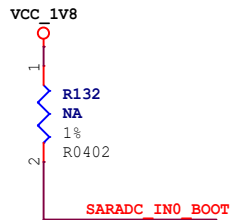

输入电压监测
 输入电压=读数电压x11
 如读数电压1.0v, 则电池对于1.0x11=11v

电池监测
 电池电压=读数电压x6.1
 如读数电压1.2v, 则电池对于1.2x6.1=7.32v

TABLE

Item	Rup	Rdown	ADC	BOOT MODE
LEVEL1	DNP	100K	0	USB (Maskrom mode)
LEVEL2	100K	12K	114	
LEVEL3	100K	27K	228	FSPI--USB
LEVEL4	100K	51K	342	
LEVEL5	100K	82K	456	
LEVEL6	100K	120K	570	EMMC--USB
LEVEL7	100K	200K	683	EMMC--SD Card--USB
LEVEL8	100K	330K	796	SD Card--USB
LEVEL9	100K	820K	910	
LEVEL10	100K	DNP	1023	FSPI--EMMC--SD Card--USB

HINLINK			
Project:	RK3528_H29K	 HINLINK	
File:	07.RK3528 SARADC/OTP		
Date:	Saturday, November 23, 2024	Rev:	<Revision>
Designer:	<designer>	Sheet:	8 of 26

RK3528_L (HDMI PHY)

U11L

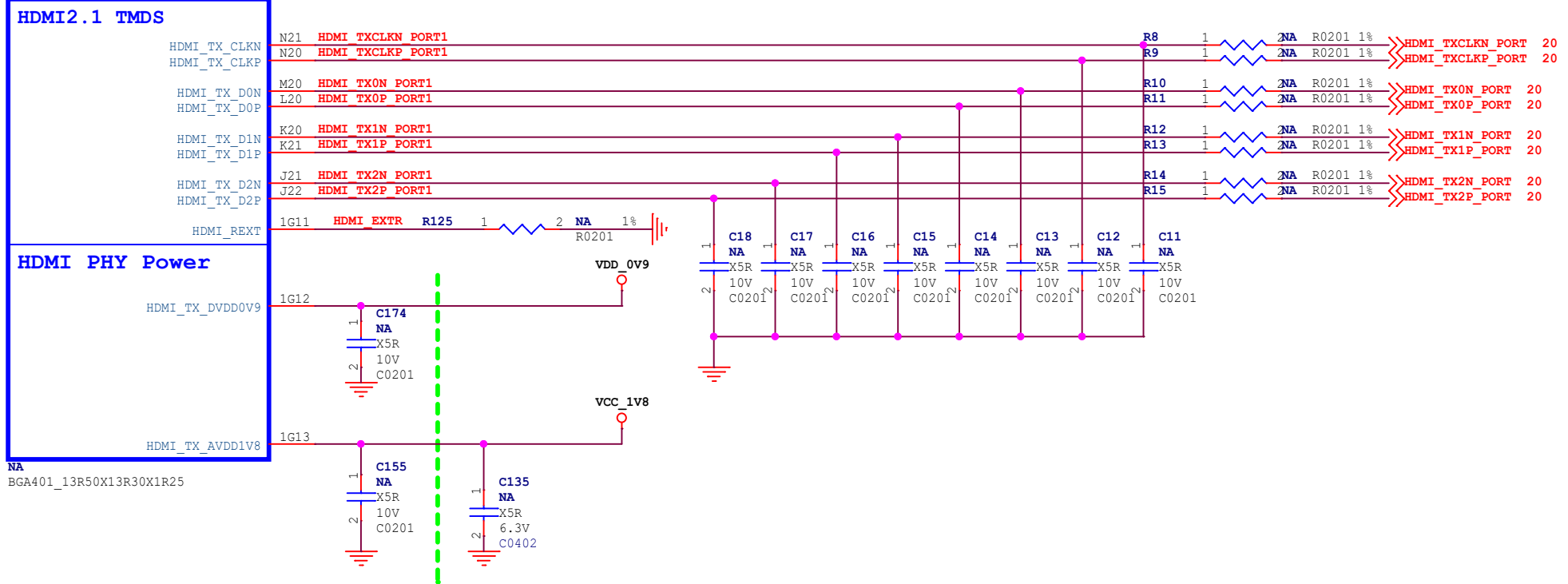

NA
BGA401_13R50X13R30X1R25

Note:
Caps of between dashed green lines and U1000 should be placed under the U1000 package.
Other caps should be placed close to the U1000 package

HINLINK		
Project:	RK3528_H29K	
File:	08.RK3528 HDMI Interface	
Date:	Saturday, November 23, 2024	Rev: <Revision>
Designer:	<designer>	Sheet: 9 of 26

RK3528_M (Acodec/VDAC)

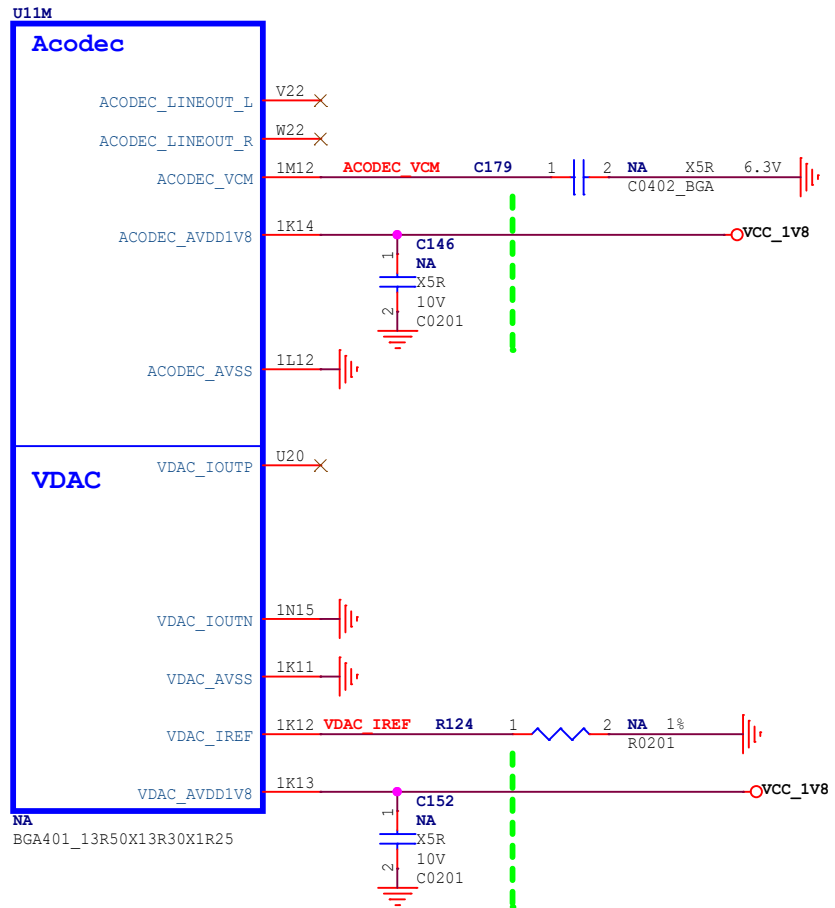

Note:
Caps of between dashed green lines and U1000 should be placed under the U1000 package.
Other caps should be placed close to the U1000 package

HINLINK			
Project:	RK3528_H29K	 HINLINK	
File:	09.RK3528 AV OUT		
Date:	Saturday, November 23, 2024	Rev:	<Revision>
Designer:	<designer>	Sheet:	10 of 26

RK3528_K (Embed FEPHY)

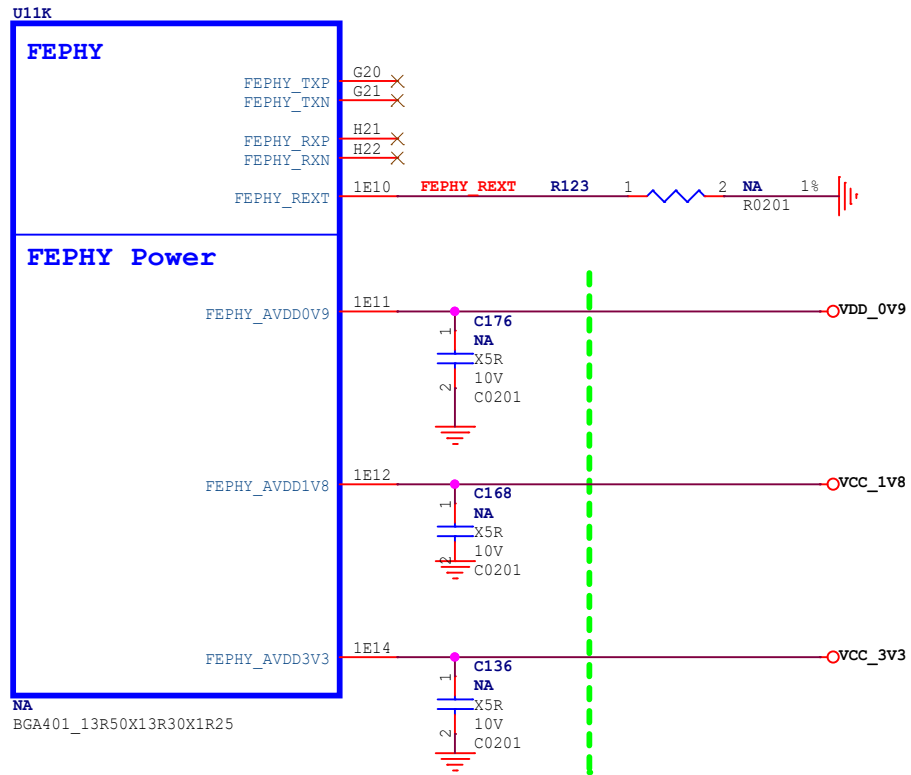

Note:

Caps of between dashed green lines and U1000 should be placed under the U1000 package.
 Other caps should be placed close to the U1000 package

HINLINK

Project:	RK3528_H29K	
File:	10.RK3528 Embed FEPHY	
Date:	Saturday, November 23, 2024	Rev: <Revision>
Designer:	<designer>	Sheet: 11 of 26

RK3528_D (VCCIO0 Domain)

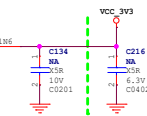
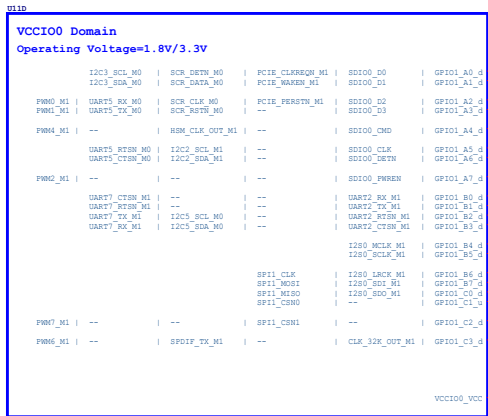

Note:
Caps of between dashed green lines and U1000 should be placed under the U1000 package. Other caps should be placed close to the U1000 package

软件调试Note:
H29K与HT2一模一样，就是新增了：5G模块和5G相关IO屏幕IO

软件调试Note:
SPI彩色屏幕

RK3528_G (VCCIO3 Domain)

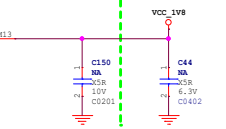
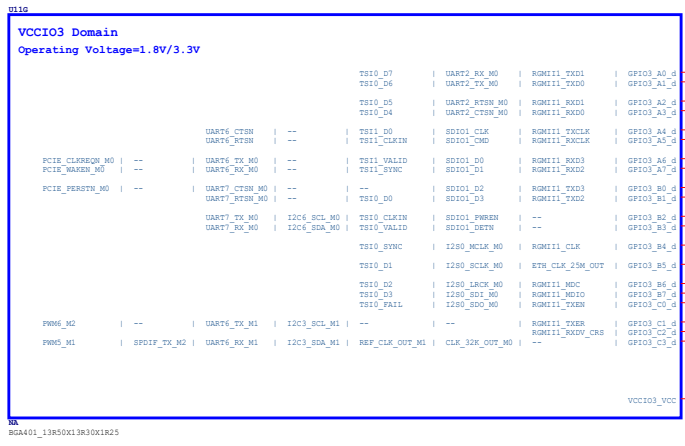

Note:
Caps of between dashed green lines and U1000 should be placed under the U1000 package. Other caps should be placed close to the U1000 package

RK3528_H (VCCIO4 Domain)

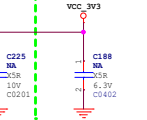
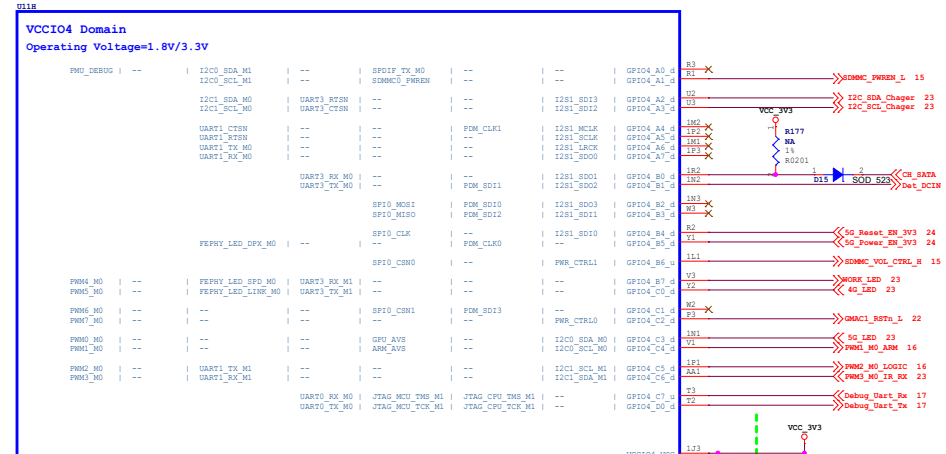

Note:
Caps of between dashed green lines and U1000 should be placed under the U1000 package. Other caps should be placed close to the U1000 package

软件调试Note:
CH SATA
电池充满电状态捕获，低电平为充电，高电平为充满或者关闭
Det_DCCIN
监测TYPE-C有电源输入
5G Reset_EN_3V3
输出高店电平，5G模块复位引脚则为低

GPI04_C0的4G LED
在CPE中代表4G网络，在安卓系统中代表网络连接
GPI04_C3的5G LED
在CPE中代表5G网络

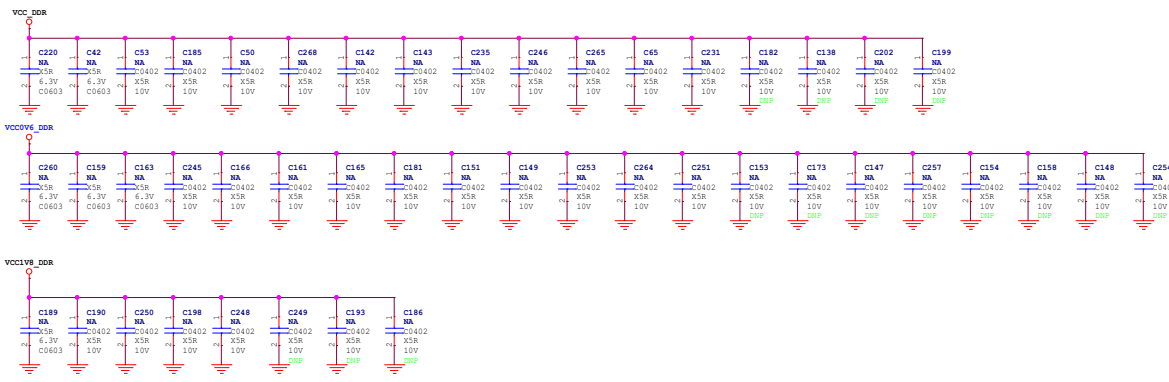
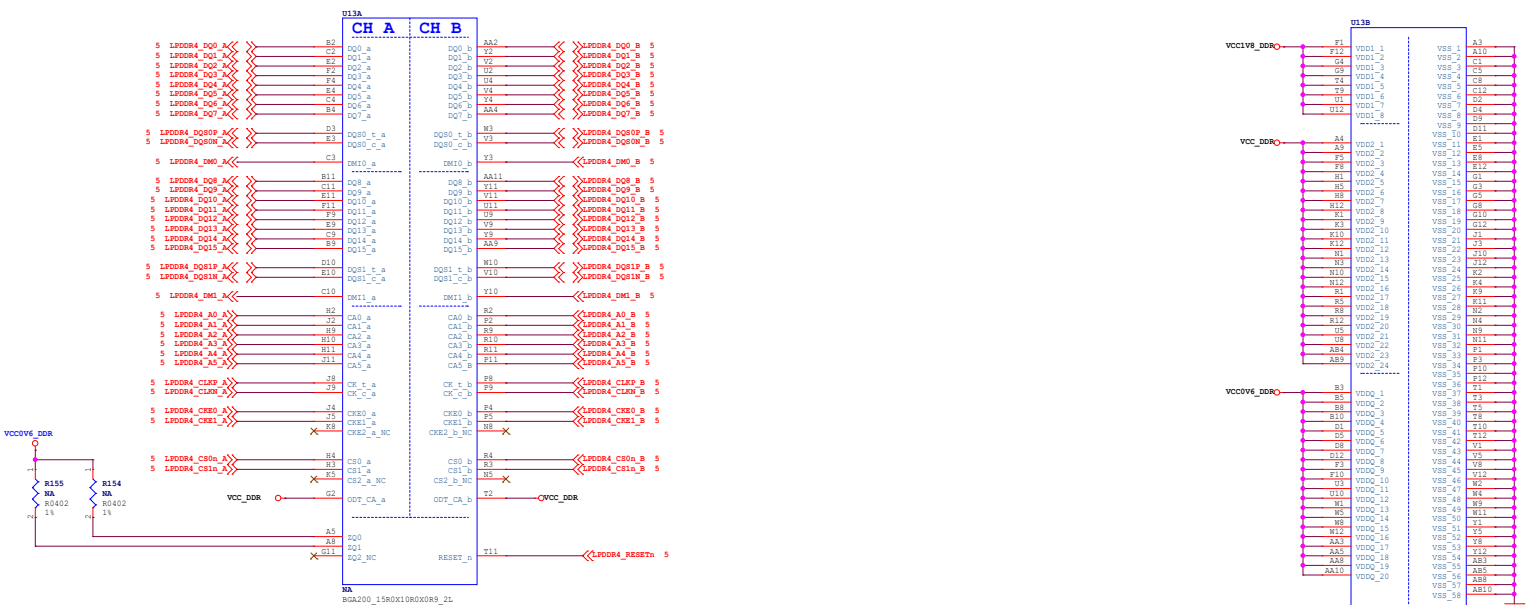

VCCV6_DDR

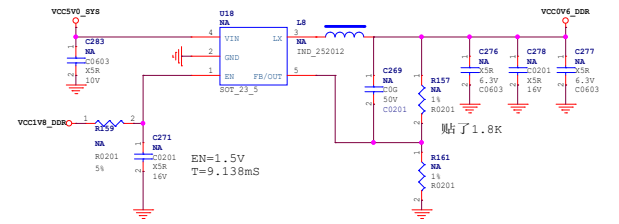

VCCV8_DDR

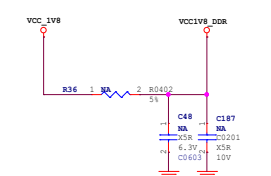

EMMC

FSPI

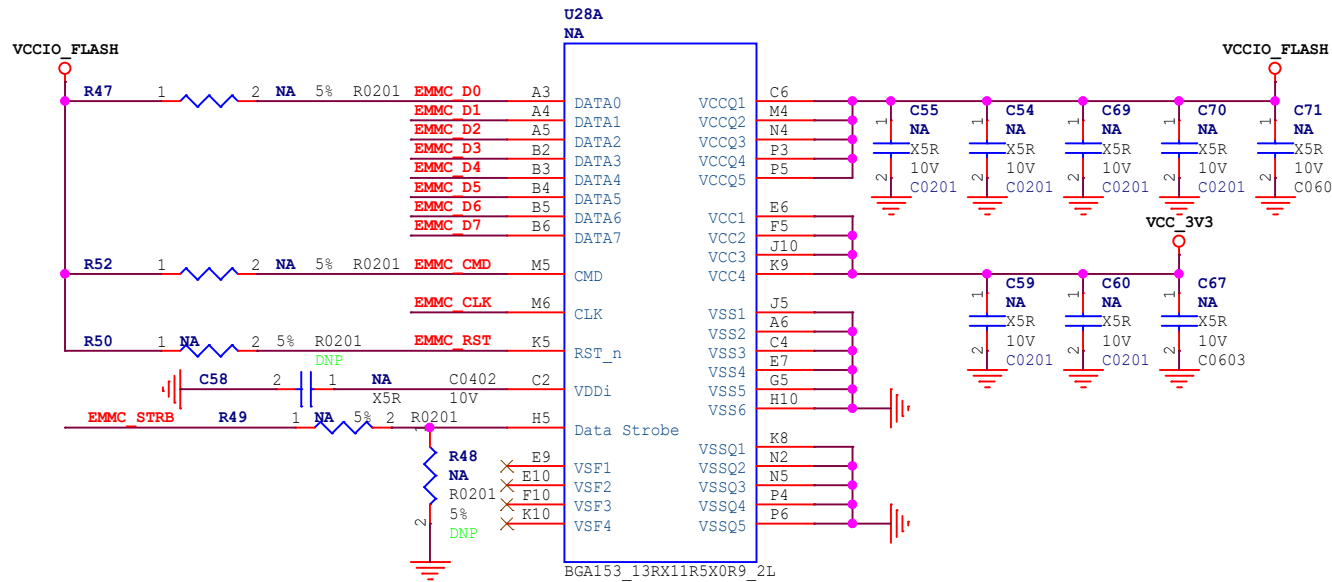
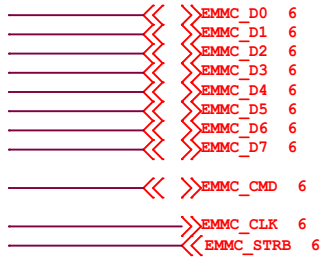

U28B	NA	A7	E5	E8	G3	G10	K6	K7	P7	P10	P10	
A2	NC2	REF01	NC196	P14								
A8	NC8	REF02	NC195	P13								
A9	NC9	REF03	NC194	P12								
A10	NC10	REF04	NC193	P11								
A11	NC11	REF05	NC191	P8								
A12	NC12	REF06	NC190	P2								
A13	NC13	REF07	NC184	P1								
A14	NC14	REF08	NC183									
B1	NC15	REF09	NC182	N14								
B7	NC21		NC181	N13								
B8	NC22		NC180	N12								
B9	NC23		NC179	N11								
B10	NC24		NC178	N10								
B11	NC25		NC177	N9								
B12	NC26		NC176	N8								
B13	NC27		NC175	N7								
B14	NC28		NC174	N6								
C1	NC29		NC173	N5								
C3	NC31		NC172	N4								
C7	NC35		NC171	N3								
C8	NC36		NC170	N2								
C9	NC37		NC169	N1								
C10	NC38		NC168	M14								
C11	NC39		NC167	M13								
C12	NC40		NC166	M12								
C13	NC41		NC165	M11								
C14	NC42		NC164	M10								
D1	NC43		NC163	M9								
D2	NC44		NC162	M8								
D3	NC45		NC161	M7								
D4	NC46		NC160	M6								
D12	NC54		NC159	M5								
D13	NC55		NC158	M4								
D14	NC56		NC157	M3								
E1	NC57		NC156	M2								
E2	NC58		NC155	M1								
E3	NC59		NC154	L14								
E12	NC68		NC153	L13								
E13	NC69		NC152	L12								
E14	NC70		NC151	L11								
F1	NC71		NC150	L10								
F2	NC72		NC149	L9								
F3	NC73		NC148	L8								
F12	NC82		NC147	L7								
F13	NC83		NC146	L6								
F14	NC84		NC145	L5								
G1	NC85		NC144	L4								
G2	NC86		NC143	L3								
G12	NC96		NC142	L2								
G13	NC97		NC141	L1								
G14	NC98		NC140	K14								
			NC139	K13								
			NC138	K12								
			NC137	K11								
			NC136	K10								
			NC135	K9								
			NC134	K8								
			NC133	K7								
			NC132	K6								
			NC131	K5								
			NC130	K4								
			NC129	K3								
			NC128	K2								
			NC127	K1								
			NC126	J14								
			NC125	J13								
			NC124	J12								
			NC123	J11								
			NC122	J10								
			NC121	J9								
			NC120	J8								
			NC119	J7								
			NC118	J6								
			NC117	J5								
			NC116	J4								
			NC115	J3								
			NC114	J2								
			NC113	J1								
			NC112	H14								
			NC111	H13								
			NC110	H12								
			NC109	H11								
			NC108	H10								
			NC107	H9								
			NC106	H8								
			NC105	H7								
			NC104	H6								
			NC103	H5								
			NC102	H4								
			NC101	H3								
			NC100	H2								
			NC99	H1								

BGA153_13RX11R5X0R9_2L

HINLINK		
Project:	RK3528_H29K	
File:	13.Flash-eMMC	
Date:	Saturday, November 23, 2024	Rev: <Revision>
Designer:	<designer>	Sheet: 14 of 26

TF Card

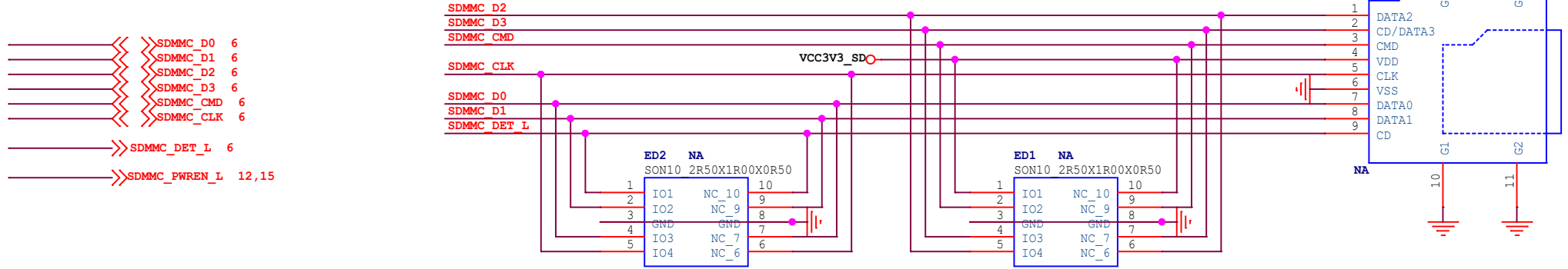

VCCIO_SD

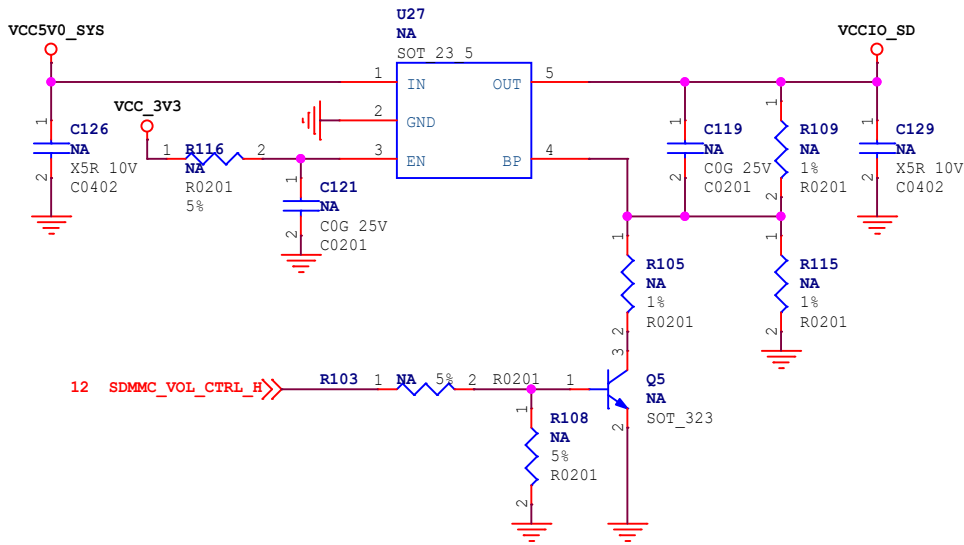

VCC3V3_SD

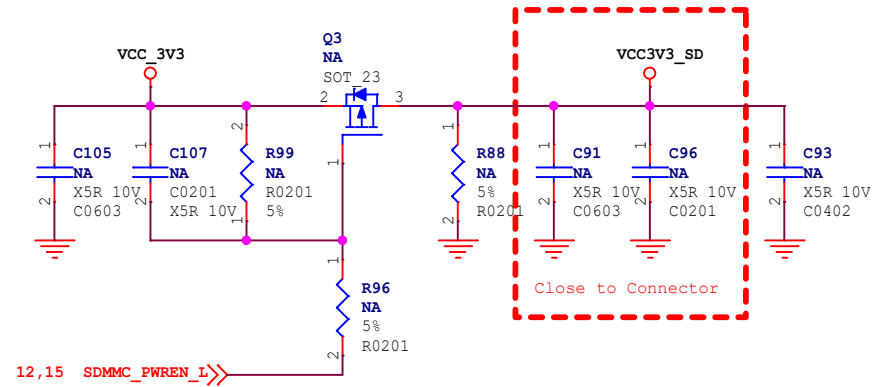

SDMMC_PWREN=L VCC_SD=3.3V(Default)
SDMMC_PWREN=H VCC_SD=0V

SDIO2.0 SDMMC0_VOL_CTRL=H VCCIO_SD=3.34V(Default)
SDIO3.0 SDMMC0_VOL_CTRL=L VCCIO_SD=1.816V

HINLINK

Project:	RK3528_H29K	
File:	14.Flash-Micro-SD Card	
Date:	Saturday, November 23, 2024	Rev: <Revision>
Designer:	<designer>	Sheet: 15 of 26

VCC5V0_SYS-->VDD_LOGIC

Step 1

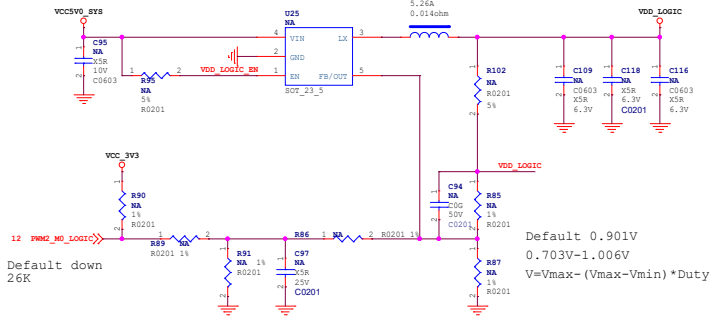

VCC5V0_SYS-->VDD_ARM

Step 1

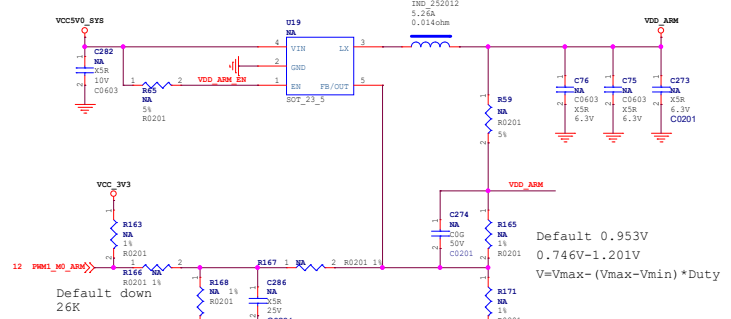

VCC5V0_SYS-->VDD_0V9

Step 1

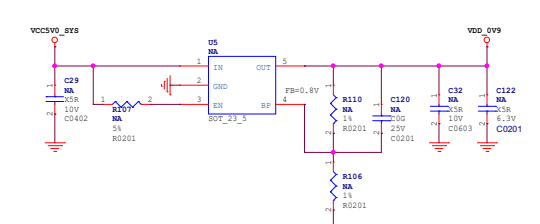

VCC_3V3->VCC_1V8(LDO)

Step 2

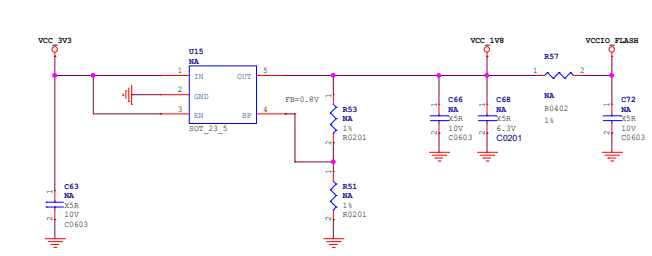

VCC5V0_SYS-->VCC_DDR

Step 2

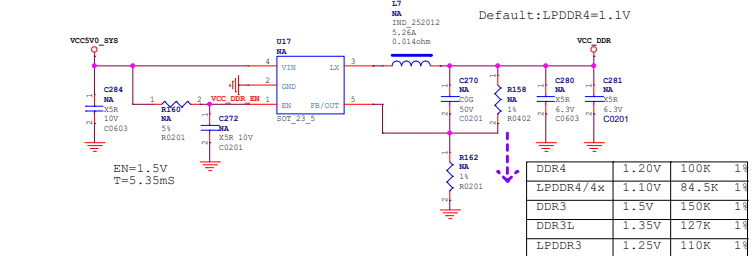

VCC5V0_SYS-->VCC_3V3

Step 2

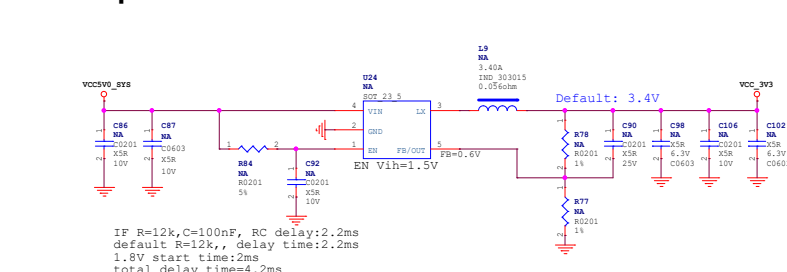

供电IC

HINLINK

Project:	RK3528_H29K	 HINLINK
File:	16.Power-DCIN	
Date:	Tuesday, January 07, 2025	Rev: <Revision>
Designer:	<designer>	Sheet: 17 of 26

5

4

3

2

1

D

D

C

C

B

B

A

A

充电IC

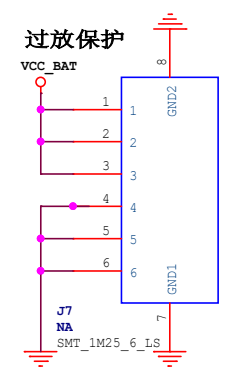

HINLINK		
Project:	RK3528_H29K	 HINLINK
File:	17.Power_Charge	
Date:	Tuesday, January 07, 2025	Rev: <Revision>
Designer:	<designer>	Sheet: 18 of 26

5

4

3

2

1

USB2.0 HOST1

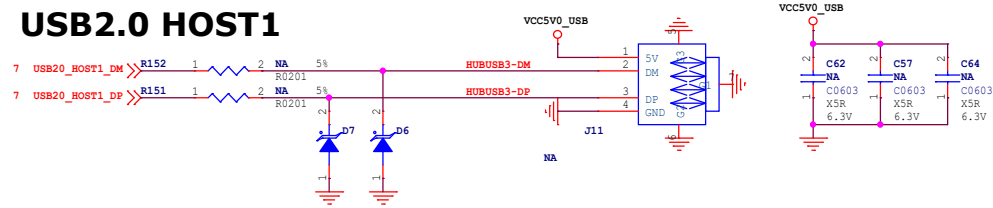

5V 500mA

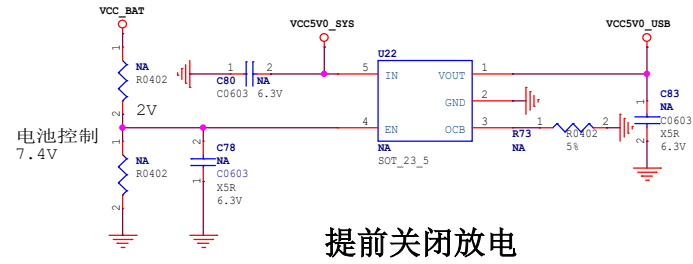

提前关闭放电

HINLINK

Project:	RK3528_H29K	 HINLINK
File:	18.USB_A	
Date:	Saturday, November 23, 2024	Rev: <Revision>
Designer:	<designer>	Sheet: 19 of 26

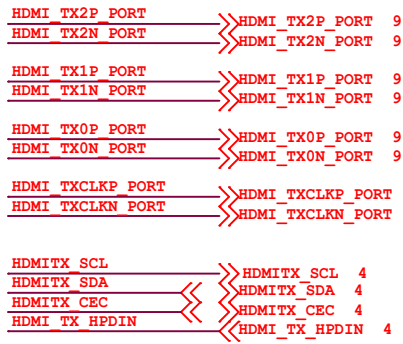

HDMI TX DDC

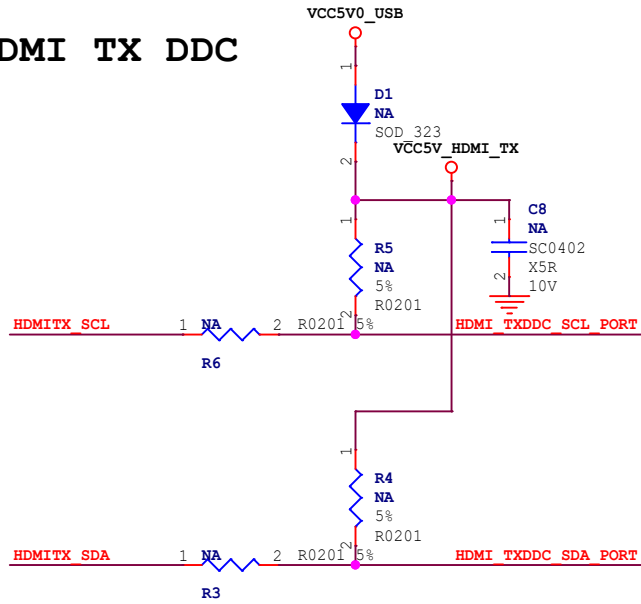

HDMI TX CEC



HDMI TX HPD

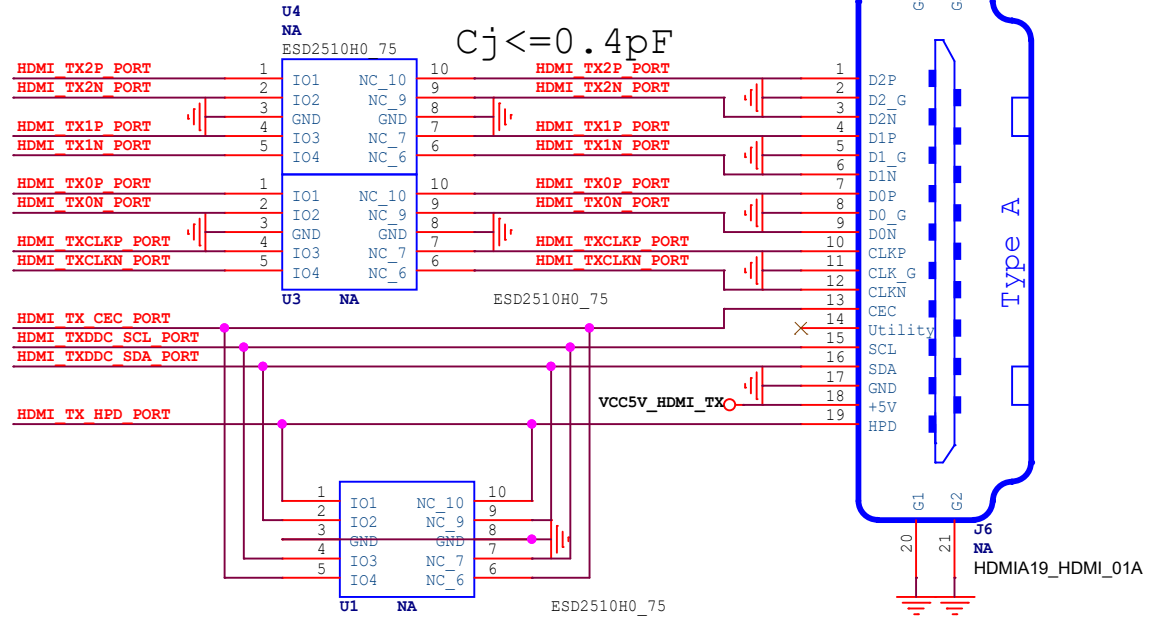
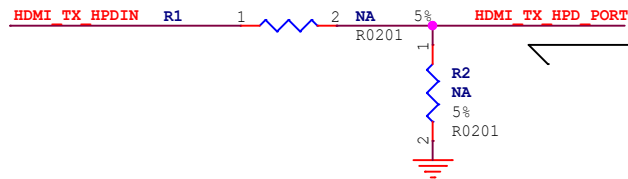

OWLVisionTech			
Project:	RK3528_H29K	 OWLVisionTech	
File:	19.VO-HDMI2.0 TX		
Date:	Saturday, November 23, 2024	Rev:	<Revision>
Designer:	<designer>	Sheet:	20 of 26

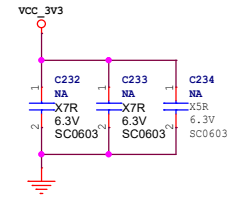
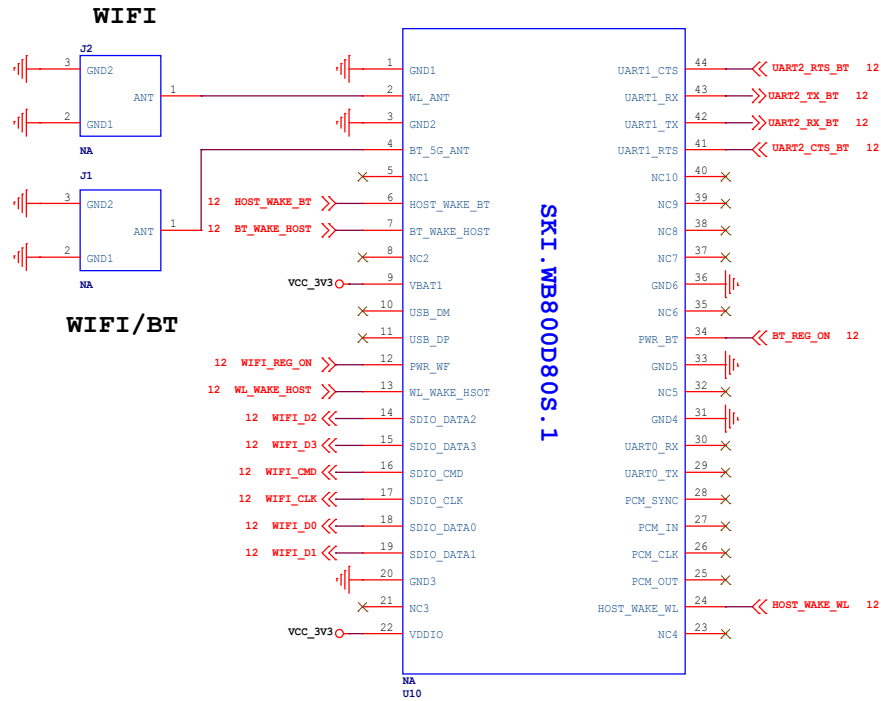

HINLINK			
Project:	RK3528_H29K		HINLINK
File:	20.SDIO WIFI		
Date:	Saturday, November 23, 2024	Rev:	<Revision>
Designer:	<designer>	Sheet:	21 of 26

RGMI I

- >>> GMAC1_TXD0 12
- >>> GMAC1_TXD1 12
- >>> GMAC1_TXD2 12
- >>> GMAC1_TXD3 12
- >>> GMAC1_TXEN 12
- >>> GMAC1_TXCLK 12
- >>> GMAC1_RXD0 12
- >>> GMAC1_RXD1 12
- >>> GMAC1_RXD2 12
- >>> GMAC1_RXD3 12
- >>> GMAC1_RXDV_CRS 12
- <<< GMAC1_RXCLK 12
- >>> GMAC1_MCLKINOUT 12
- >>> GMAC1_MDC 12
- <<< GMAC1_MDIO 12
- >>> GMAC1_RSTn_I 12

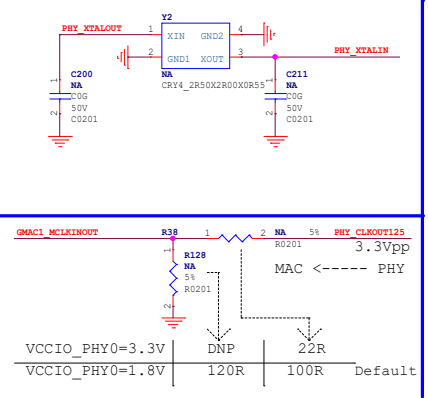

VCCIO_PHY0=3.3V
VCCIO_PHY0=1.8V

DNP 120R
22R 100R Default

MAC <--- PHY

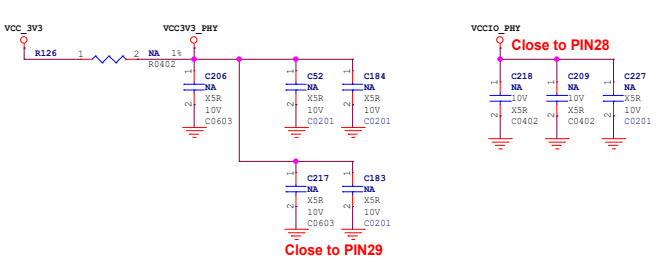
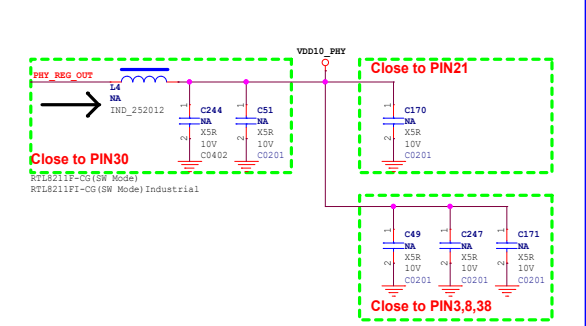
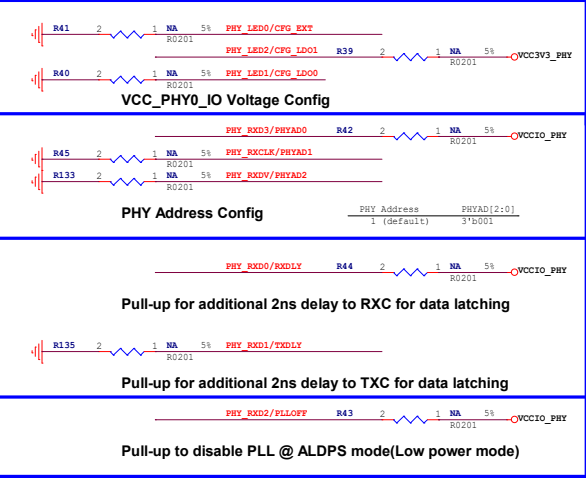
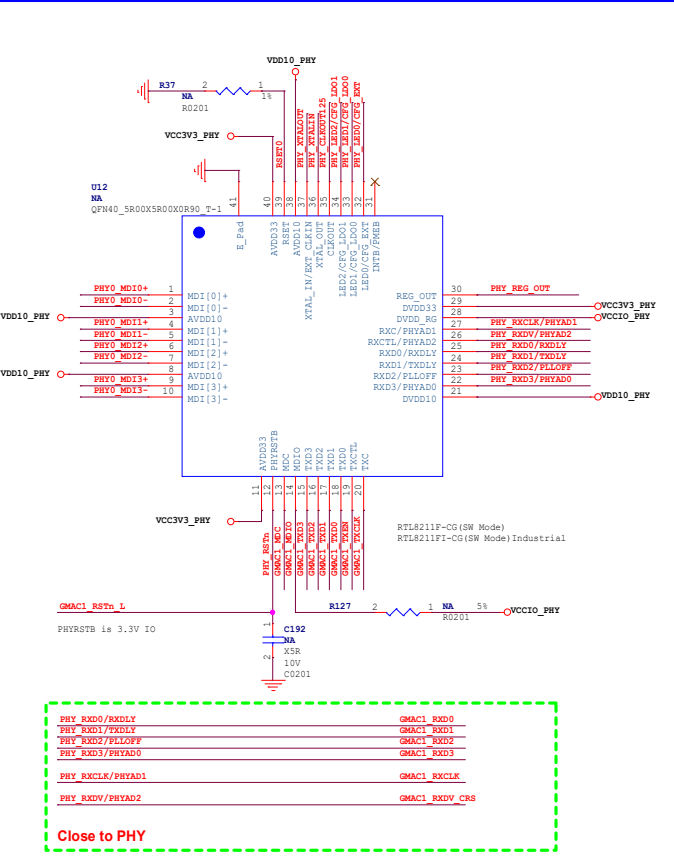
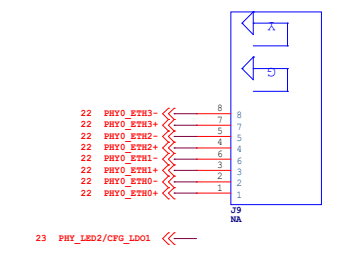
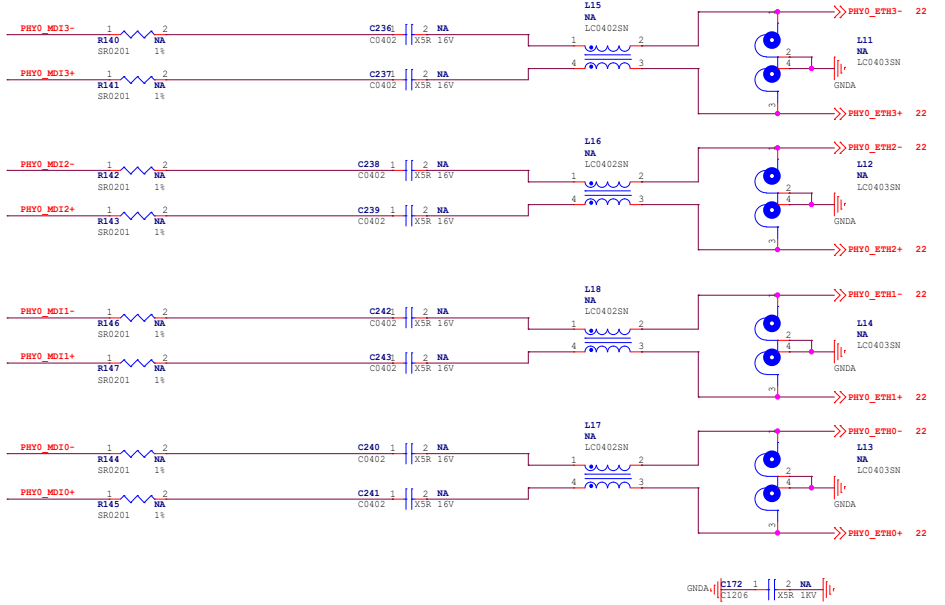

KEY

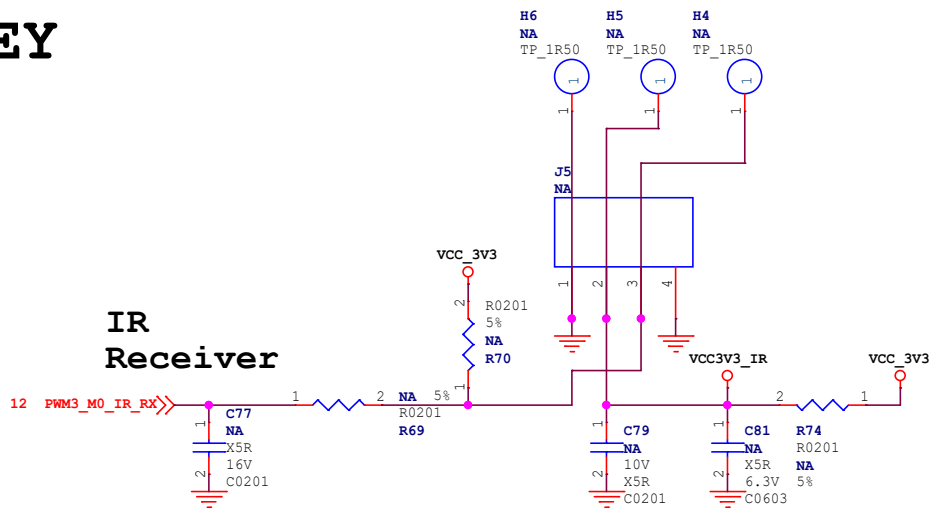

屏幕

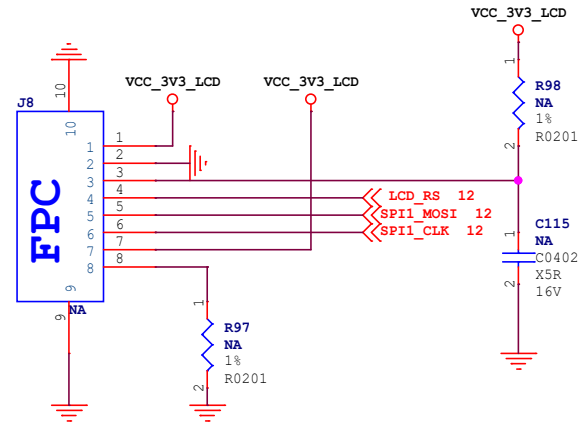

增加背光控制

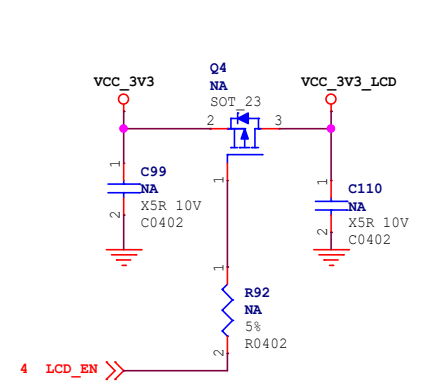

7号灯

电源灯

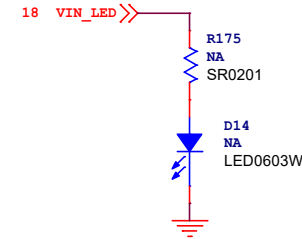

红色灯

1号灯

4G灯

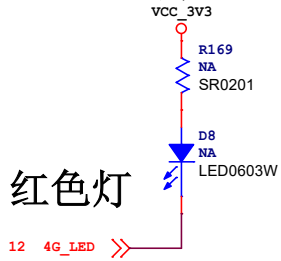

红色灯

2号灯

5G灯

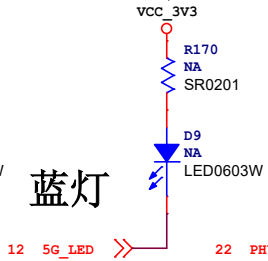

蓝灯

3号灯

网口

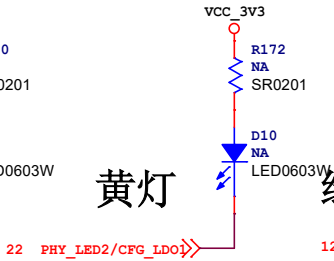

黄灯

4号灯

工作灯

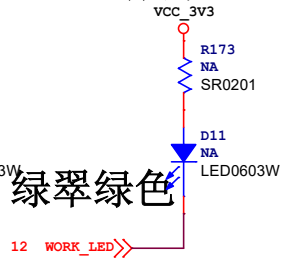

绿翠绿色

5号灯

放电灯

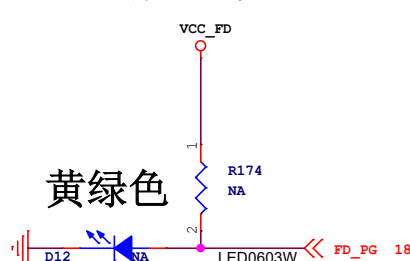

黄绿色

6号灯

充电灯

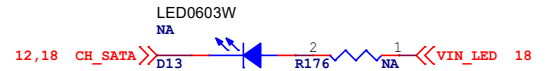

白色灯

HINLINK

Project:	RK3528_H29K	
File:	22.Key/HW ID/LED	
Date:	Tuesday, January 07, 2025	Rev: <Revision>
Designer:	<designer>	Sheet: 23 of 26

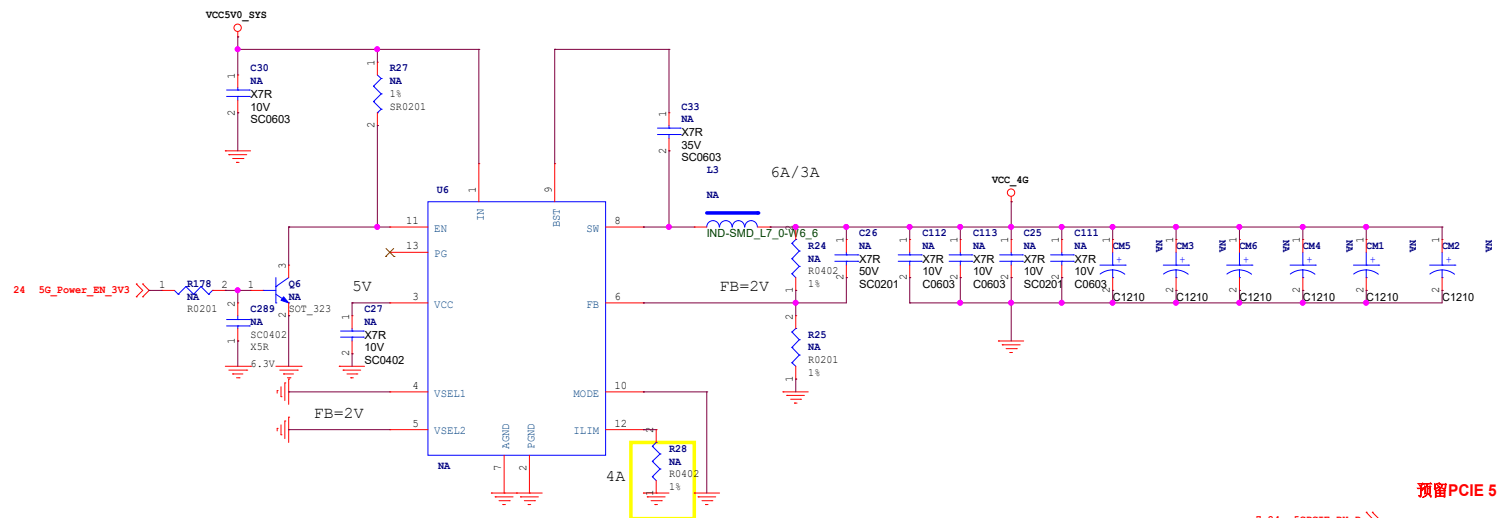

预留PCIE 5G模块

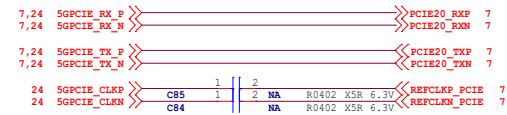

M2_NGFF-4G/5G

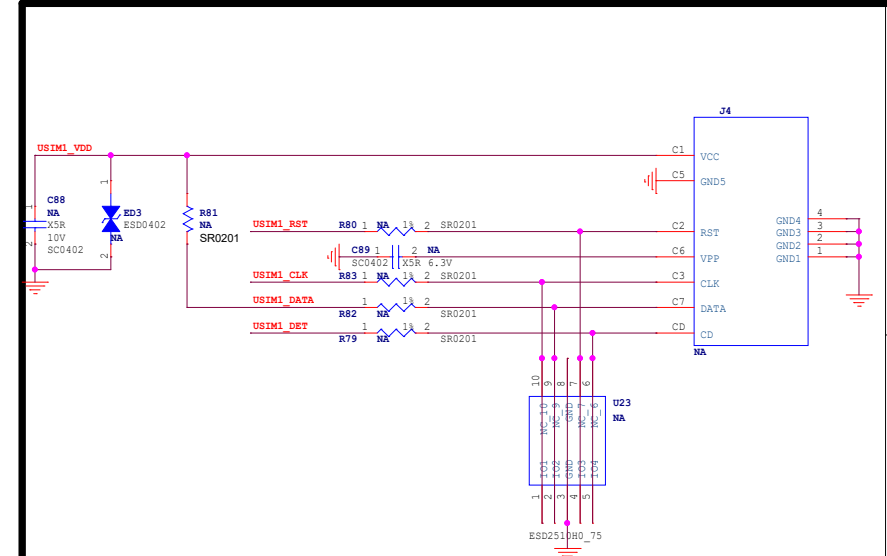
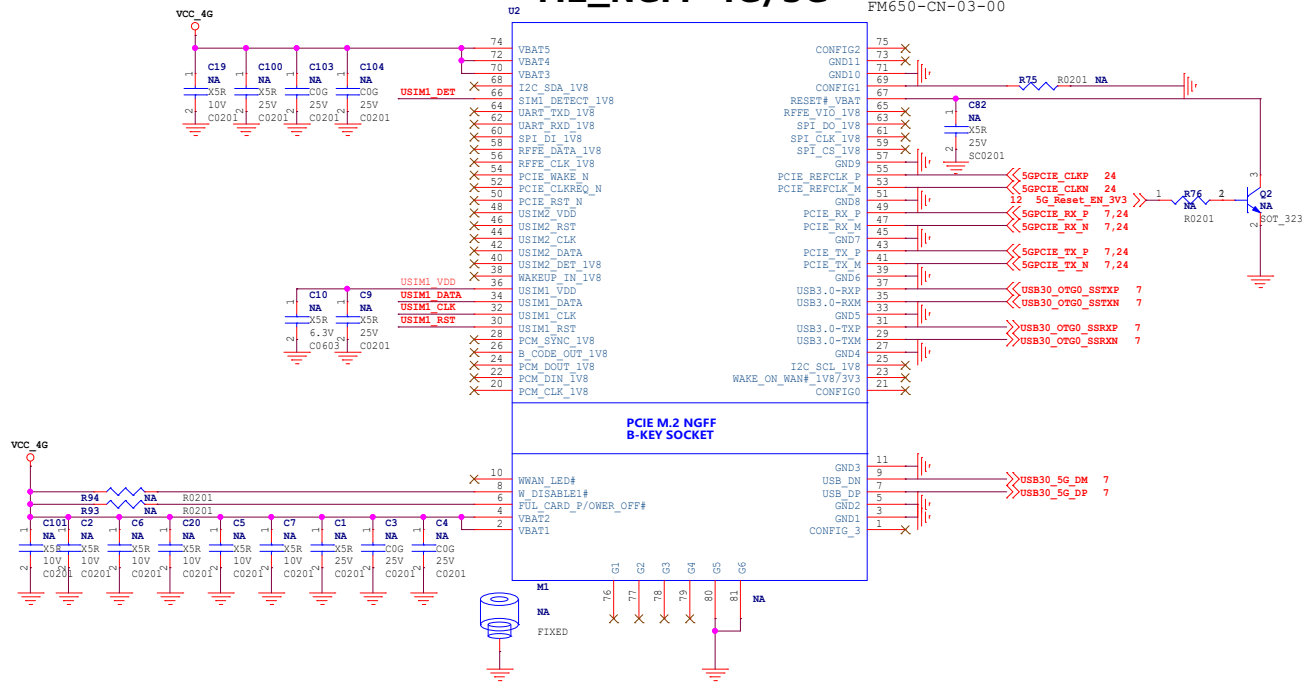

HINLINK		
Project:	RK3528_H29K	
File:	23.4G/5G-MODULE	
Date:	Saturday, November 23, 2024	Rev: <Revision>
Designer:	<designer>	Sheet: 24 of 26

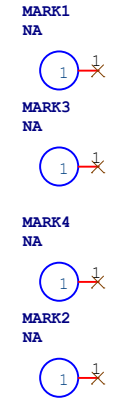
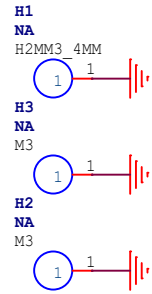
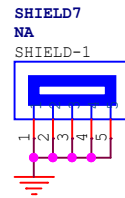
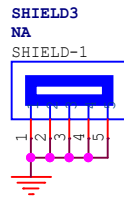
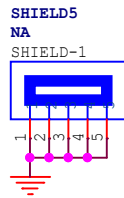
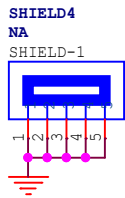
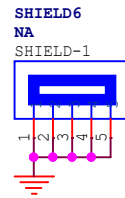
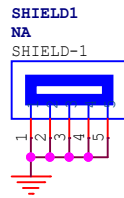
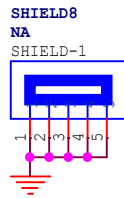
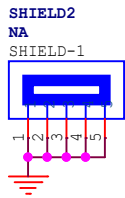

HINLINK		
Project:	RK3528_H29K	 HINLINK
File:	24.Mark/Hole	
Date:	Saturday, November 23, 2024	Rev: <Revision>
Designer:	<designer>	Sheet: 25 of 26